



When you want pins with special shapes such as tapers or contours - special head sizes- special hardness, special material up to any length.

DME has the manufacturing, heat treating and sophisticated quality control equipment to meet your requirements for special ejector pins, core pins or ejector sleeves.

Special pins match the precision manufacturing of all our standards in every detail.



Step 1: Photocopy this form.

Step 2: Specify required tolerances on all dimensions.

Step 3: Contact **M-D-S** on 021 555 2701

Special Pins

Comments:

.....

Company:.....

Contact:.....

Tel:.....

Fax:.....

Quantity:.....

Mat:.....

Hardness:..... HRC

Delivery date:

Nitrite: Yes

Signature:.....

Order Number:.....

Comments:

.....

Company:.....

Contact:.....

Tel:.....

Fax:.....

Quantity:.....

Mat:.....

Hardness:..... HRC

Delivery date:

Nitrite: Yes

Signature:.....

Order Number:.....

Comments:

.....

Company:.....

Contact:.....

Tel:.....

Fax:.....

Quantity:.....

Mat:.....

Hardness:..... HRC

Delivery date:

Nitrite: Yes

Signature:.....

Order Number:.....

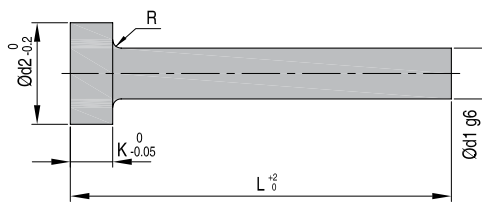

	Dim.	Tol.
d1		
d2		
K		
R		
L		

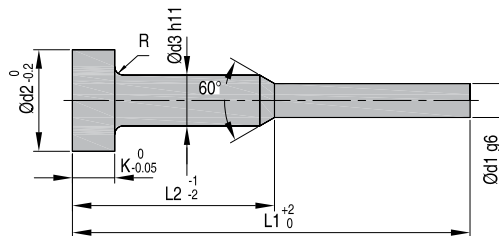

	Dim.	Tol.
d1		
d2		
d3		
L1		
L2		
K		
R		

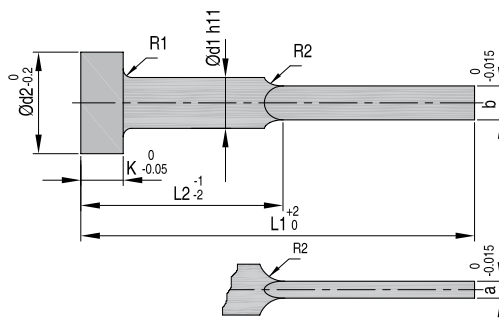

	Dim.	Tol.
d1		
d2		
K		
R1		
R2		
a		
b		
L1		
L2		