

Diprofil Files & Tools

4







Diprofil

Di-Pro	2
Classic	7
Protective Finger Sleeves	12
Dipromini	14
Dipromini Transverse	19
Rotary Handpieces	26
Drive Sources	28
Diamond Files.....	32
Diamond and CBN Rotary Tools.....	47
Precision CBN Tools.....	58
Polishing, Lapping & Honing Tools.....	62
Polishing Stones.....	66
Tool Holders.....	69
Precision Steel Files	74

Sets

Sets.....	76
-----------	----

Other Files

Diamond Files.....	79
--------------------	----



Info

Di-Pro polishing/filing machines



The Di-Pro™ represents a new standard of high-end polishing/filing machines with an increased focus on the operator's well-being. The low levels of vibration greatly reduce the risk of Hand Arm Vibration Syndrome (HAVS) – without compromising performance.

The dangers of Hand-Arm Vibrations (HAV) have in recent years been focused as one of the main occupational hazards all over the vibrating tools-using industry. With this in mind Diprofil has developed a high quality low-vibrating machine with reduced vibration levels and the same renowned quality standard as the Classic Diprofil Machine. To achieve as low vibration levels as possible, the Di-Pro™ has been optimized for tools within a certain weight-span. This is based on Diprofil's long experience in tools normally used with this type of machine and keeping within this weight-span gives optimal efficiency in relation to the vibration levels.

For the best efficiency to vibration-ratio, the following tools are recommended:

- Diprofil diamond files type DLA, DLE, DLF, DLM and DBE
- Selected Diprofil lapping tools
- Selected Diprofil polishing tools
- Di-Pro stoning- & polishing tools

The Di-Pro™ is available with the following drive sources:

- Flexible shaft connection (slip-joint / ball-joint)
- Integrated micro-motor
- Integrated air-motor



Flexible-shaft driven machine with slip-joint connection (European standard)

FXB - FXK

REF	Tool holder	€
FXB	Ø 3,5 mm	1291,83
FXK	Ø 6,4 mm	1426,4



Drive:	The FXB and FXK models should be driven by an electrical hanging-motor with speed control and a flexible-shaft with slip-joint connection (European standard) e.g. Diprofil type DSE-47. Corresponding motors of other brands may also be used.	
Speed (maximum):	7.000 rpm	
Speed (recommended):	5.000 – 7.000 rpm (depending on the weight of the used tool).	
Stroke length:	0 – 6 mm (recommended 0,5 – 4 mm NOTE! At stroke lengths exceeding 4 mm a maximum speed of 5.000 rpm is recommended.	
Weight:	FXB: 740 g	FXK: 780 g
Noise level:	not exceeding 75 dB A at 7.000 rpm	
Vibration levels:	Not exceeding 2,5 m/s ² when the machine is operated according to the operation guide.	

For more information about vibration levels when using certain tools at different speeds and stroke lengths, please see the operation guide. Frequency weighed hand/arm vibration principally in accordance with ISO 28927-8.



FXD - FXL

Air driven machine



REF	Tool holder	€
FXD	Ø 3,5 mm	1875,04
FXL	Ø 6,4 mm	2007,33

Drive:

The FXD and FXL models have a built in air-motor and should be driven by compressed and oil mist lubricated air. PLEASE NOTE! The built-in air-motor may be damaged, if operated with un-lubricated air. Connection: The Diprofil quick-coupling HSL-M and fog lubrication unit MFB should be used for connection to your compressed air system.

PLEASE NOTE! Protect the air inlet from dust and dirt, when not in operation.

Speed (maximum):

7.000 rpm

Speed (recommended):

5.000 – 7.000 rpm (depending on the weight of the used tool).

Stroke length:

0 – 6 mm (recommended 0,5 – 4 mm) NOTE! At stroke lengths exceeding 4 mm a maximum speed of 5.000 rpm is recommended.

Weight:

FXD: 880 g FXL: 920 g

Oil consumption:

minimum 30 mm³/min. at maximum speed (about 2 drops/min.)

Air pressure:

4 bar (57psi)

Air consumption:

Approx. 60 l/min at 7.000 rpm

Noise level:

not exceeding 75 dB A at 7.000 rpm

Vibration levels:

Not exceeding 2,5 m/s² when the machine is operated according to the operation guide.

For more information about vibration levels when using certain tools at different speeds and stroke lengths, please see the operation guide. Frequency weighed hand/arm vibration principally in accordance with ISO 28927-8.



Machine with built-in micro-motor (Diprofil connector)

FXP - FXM

REF	Tool holder	€
FXP	Ø 3,5 mm	1863,54
FXM	Ø 6,4 mm	1995,82



Drive:	The FXP and FXM models have a built-in micro-motor, which is connected to, and controlled by, the DIPROFIL DPU-3, TPU-20 or corresponding power units.
Speed (maximum):	7.000 rpm
Speed (recommended):	5.000 – 7.000 rpm (depending on the weight of the used tool).
Stroke length:	0 – 6 mm (recommended 0,5 – 4 mm) NOTE! At stroke lengths exceeding 4 mm a maximum speed of 5.000 rpm is recommended.
Weight:	FXP: 960 g FXM: 980 g
Noise level:	not exceeding 75 dB A at 7.000 rpm
Vibration levels:	Not exceeding 2,5 m/s ² when the machine is operated according to the operation guide.

For more information about vibration levels when using certain tools at different speeds and stroke lengths, please see the operation guide. Frequency weighed hand/arm vibration principally in accordance with ISO 28927-8.

4



FXB - FXK

Spare parts

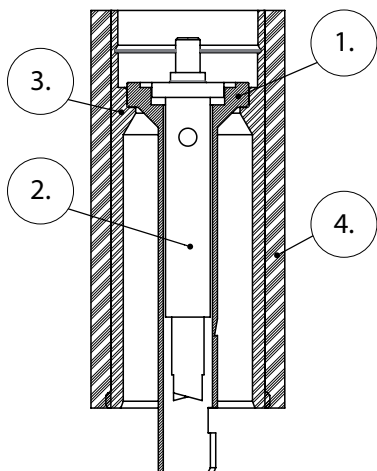

Slip-joint Connection Diprofil Di-Pro Machines: No. 400 or higher. Item No.: FXB and FXK.

Pos.	REF	Description.
1.	FXA-21.	Connecting sleeve.
2.	FXA-22.	Spindle drive mounting.
3.	FXA-23.	Handle sleeve.
4.	FXA-24.	Handle sleeve cover.

(All Parts 20mm longer, than on older machines)

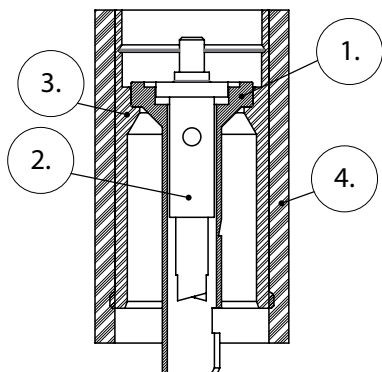

Slip-joint Connection Diprofil Di-Pro Machines: 1 Older, No.001 to 399. Item No.: FXB and FXK.

Pos.	REF	Description.
1.	FMK-2.	Connecting sleeve.
2.	FMK-3.	Spindle drive mounting.
3.	FMK-1.	Handle sleeve.
4.	FXA-15.	Handle sleeve cover.



Original reciprocating polishing/filing machine

Info



The Original Diprofil Reciprocating Filing Machines are designed for efficient polishing and finishing operations.

The Diprofil Machines, with a wide range of tools and accessories, have been developed by careful studies of fine mechanical handwork and finishing operations. They facilitate filing, lapping, honing, polishing etc. and have become an important concept in the daily work of moldmaking, die-sinking, toolmaking and other fine mechanical precision work.

All Diprofil Machines are delivered in a handy tool-box with the necessary accessories.

4



FPD/R - FPL/R

Air drive



REF	Old DME REF	Tool holder	€
FPD/R	HDL 50	Ø 3,5 mm	1607,82
FPL/R	HDL 100	Ø 6,4 mm	1658,78

The air-driven Original Diprofil Filing Machine, has a specially developed 18-cylinder radial piston-type air motor with integrated speed regulator.

The machine is available with a Ø 3,5 mm tool holder (FPD/R) or a Ø 6,4 mm tool holder (FPL/R).

The airmotors are manufactured with a very high level of accuracy and require lubricated and filtered air (5µ) to obtain a long and trouble-free lifetime.

For better comfort, each model is fitted with an ergonomic rubber sleeve.

Technical data

Stroke length:	0-6 mm (recommended 0,5-3mm)
Speed:	max 8.000 rpm (recommended: 5.000 - 7.000 rpm)
Weight:	750 - 780 g
Oil consumption:	minimum 30 mm ³ /min. at maximum speed (about 2 drops/min.)
Air pressure:	FPD/R: 4 bar (57psi) FPL/R: 4 bar (57psi)
Air consumption:	FPD/R: Approx. 65 l/min at 8.000 rpm FPL/R: Approx. 60 l/min at 7.000 rpm
Noise:	< 70 dB(A) at 7.000 rpm
Vibration:	with standard tool holder (Ø 3,5 mm) 3-10 m/s ² with heavy duty tool holder (Ø 6,4 mm) 4-12 m/s ² .

Frequency weighed hand/ arm vibration, principally in accordance with ISO 28927-8. For further details, see diagram and other information in the corresponding Operation Guide.



Flexible-Shaft Drive - Slip Joint Connection

FPB/R - FPK/R

REF	Old DME REF	Tool holder	€
FPB/R	HD 50	Ø 3,5 mm	930,15
FPK/R	HD 100	Ø 6,4 mm	981



The Original Diprofil Filing Machine for flexible-shaftdrive is available for connection to Slip Joint.

The machines can be supplied with two different tool holders, standard Ø 3,5 mm (FPB/R) or heavy duty Ø 6,4 mm (FPK/R). For better comfort, each model is fitted with an ergonomic rubber sleeve.

Technical data

Stroke length: 0-6 mm (recommended 0,5-3mm)
 Speed: max 8.000 rpm (recommended: 5.000 - 7.000 rpm)
 Weight: 585 - 615 g
 Noise: < 70 dB(A) at 7.000 rpm
 Vibration: with standard tool holder (Ø 3,5 mm) 3-10 m/s²
 with heavy duty tool holder (Ø 6,4 mm) 4-12 m/s².

Frequency weighed hand/arm vibration, principally in accordance with ISO 28927-8. For further details, see diagram and other information in the corresponding Operation Guide.



FPP/R - FPM/R

Micro Motor Drive - Integrated Micro Motor



REF	Tool holder	€
FPP/R	Ø 3,5 mm	1644,85
FPM/R	Ø 6,4 mm	1696,03

The Original Diprofil Filing Machine for Micro motor drive can be supplied with two different tool-holders, standard Ø 3,5 mm (FPP/R) or heavy duty Ø 6,4 mm (FPM/R). These have a built-in micro-motor, which is connected to, and controlled by, the DIPROFIL DPU-3, TPU-20 or corresponding DME/EOC power units (e.g. Grande,...). For better comfort, each model is fitted with an ergonomic rubber sleeve. The machine is also available with Eneska 3-1 connector (FPM/ERJ, FPP/ERJ).

Technical data

Stroke length:	0-6 mm (recommended 0,5-3mm)
Speed:	max 8.000 rpm (7.000 rpm at 32V) recommended: 5.000 - 7.000 rpm
Weight:	800 - 830 g
Noise:	< 70 dB(A) at 7.000 rpm
Vibration:	with standard tool holder (Ø 3,5 mm) 3-10 m/s ² with heavy duty tool holder (Ø 6,4 mm) 4-12 m/s ² .

Frequency weighed hand/ arm vibration, principally in accordance with ISO 28927-8. For further details, see diagram and other information in the corresponding Operation Guide.



Spare Parts

FPB/R - FPK/R

Slip-joint Connection.
Diprofil Classic Machines: Item No.: FPB and FPK.

Pos.	REF	Description.
1.	FMK-2.	Connecting sleeve.
2.	FMK-3.	Spindle drive mounting.
3.	FMK-1.	Handle sleeve.
4.	FMM-9.	Rubber cover for Classic machines.

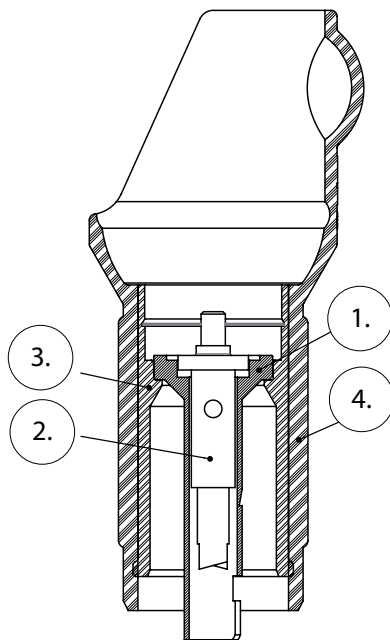

4



Info

Diprofil Protective Finger Sleeves



The old (wrong) way.....



The new (right) way!

To further emphasize our focus on the importance of reducing potentially harmful vibrations we are now introducing the new Diprofil Protective Finger Sleeve.

It's a well known fact that it's actually more common for operators to sustain vibration related injuries in the hand guiding the tool rather than in the hand holding the actual machine. With this in mind we have developed the Diprofil protective finger sleeve. The finger sleeve will improve guidance of the tool as there is no longer any need for putting your fingers on moving tools and/or machine parts.

The finger sleeve is compatible with both the Classic and the low-vibrating Di-Pro polishing-/filing machines and comes with an extension rod for longer tools in two different versions depending on the size of the original tool-holder (Ø 3,5 or 6,4 mm). For more information on each specific item please see the technical information above.

The two different models available for either 3,5 or 6,4 mm tool-holders are the following:

- | | |
|---------|---|
| PFS-3,5 | Compatible with both the Classic and the low-vibrating Di-Pro polishing-/filing machines fitted with 3,5 mm tool-holders. |
| PFS-6,4 | Compatible with both the Classic and the low-vibrating Di-Pro polishing-/filing machines fitted with 6,4 mm tool-holders. |

Both versions comes in a handy box with the necessary tools and an instruction on how to attach it to your machine.



Protective Finger Sleeve for the Ø 3,5 mm tool-holder

PFS-3,5

Outer Ø: 23 mm
Length (without extension rod): 34 mm
Length (including extension rod): 91 mm
Maximum tool shank Ø: 3,5 mm
Weight (without extension rod): 33 g
Weight (including extension rod): 50 g



REF	€
PFS-3,5	137,53

Protective Finger Sleeve for the Ø 6,4 mm tool-holder

PFS-6,4

Outer Ø: 26 mm
Length (without extension rod): 48 mm
Length (including extension rod): 105 mm
Maximum tool shank Ø: 6,4 mm
Weight (without extension rod): 49 g
Weight (including extension rod): 66 g



REF	€
PFS-6,4	149,03

4



Info

Diprofil mini polishing/filing machines



A complete system for working on difficult surfaces. Low weight and a thorough ergonomic design results in a more effective finishing and polishing work, especially in narrow and confined spaces.

The Diprofil Mini Filing Machine is available with 3 different stroke lengths. For lowest possible vibration levels we recommend using light weight tools and tool-holders. Using the Diprofil Mini Filing Machine gives you total control even when working in the most narrow spaces on a delicate workpiece.

All Dipromini machines are delivered in a handy tool-box with the necessary accessories.



Flexible-Shaft Drive - Slip Joint Connection

FMR/S...

REF	Old DME REF	Stroke length	€
FMR/S5	HDW 1	0,5 mm	501,2
FMR/S10		1,0 mm	501,2
FMR/S15	HDW 2	1,5 mm	501,2



The Diprofil Mini Polishing/Filing machine for flexible-shaft drive is available for connection to Slip Joint. There are three basic models with 0,5 mm (FMR/S5), 1,0 mm (FMR/S10) or 1,5 mm (FMR/S15) stroke length.

Technical data

Tool holder:	max Ø 3,6 mm
Stroke length:	0,5, 1,0 or 1,5 mm
Speed:	max 12.000 rpm recommended: 5.000 - 11.000 rpm
Dimension:	Ø 24 mm
Weight:	approx. 120 g
Noise:	< 70 dB(A) at 9.000 rpm
Vibrations:	stroke 0,5 mm: <2,5 m/s ² , stroke 1,0 mm: 1,5 - 3 m/s ² , stroke 1,5 mm: 1,5 - 4 m/s ²

Frequency weighed hand/arm vibration, principally in accordance with ISO 28927-8. For further details, see diagram and other information in the corresponding Operation Guide.



FMR/G...

Micro Motor Connection - Gesswein, Argofile & Uhandy



REF	Old DME REF	Stroke length	€
FMR/G5	JA 60	0,5 mm	501,2
FMR/G10		1,0 mm	501,2
FMR/G15	JA 65	1,5 mm	501,2

The Dipromini Filing Machine for Gesswein, Argofile and Uhandy connection can be supplied with three different stroke lengths: 0,5 mm (FMR/G5), 1,0 mm (FMR/G10) or 1,5 mm (FMR/G15).

Technical data

Tool holder:	max Ø 3,6 mm
Stroke length:	0,5, 1,0 or 1,5 mm
Speed:	max 12.000 rpm recommended: 5.000 - 11.000 rpm
Dimension:	Ø 24 mm
Weight:	approx. 120 g
Noise:	< 70 dB(A) at 9.000 rpm
Vibrations:	stroke 0,5 mm: <2,5 m/s ² , stroke 1,0 mm: 1,5 - 3 m/s ² , stroke 1,5 mm: 1,5 - 4 m/s ²

Frequency weighed hand/arm vibration, principally in accordance with ISO 28927-8. For further details, see diagram and other information in the corresponding Operation Guide.



Flexible-Shaft Drive - Slip Joint Connection

FMR/D...

REF	Stroke length	€
FMR/D5	0,5 mm	501,2
FMR/D10	1,0 mm	501,2
FMR/D15	1,5 mm	501,2



Dipromini polishing/filing Machine with connection for Diprofil micro motor type HPM-B1 which should be connected to, and controlled by, the DIPROFIL DPU-3, TPU-20 or corresponding power units. Available with three different stroke lengths: 0,5 mm (FMR/D5), 1,0 mm (FMR/D10) or 1,5 mm (FMR/D15).

Technical data

Tool holder:	max Ø 3,6 mm
Stroke length:	0,5, 1,0 or 1,5 mm
Speed:	max 12.000 rpm recommended: 5.000 - 11.000 rpm
Dimension:	Ø 24 mm
Weight:	approx. 120 g
Noise:	< 70 dB(A) at 9.000 rpm
Vibrations:	stroke 0,5 mm: <2,5 m/s ² , stroke 1,0 mm: 1,5 - 3 m/s ² , stroke 1,5 mm: 1,5 - 4 m/s ²

Frequency weighed hand/arm vibration, principally in accordance with ISO 28927-8. For further details, see diagram and other information in the corresponding Operation Guide.



FMR/S...

Spare parts

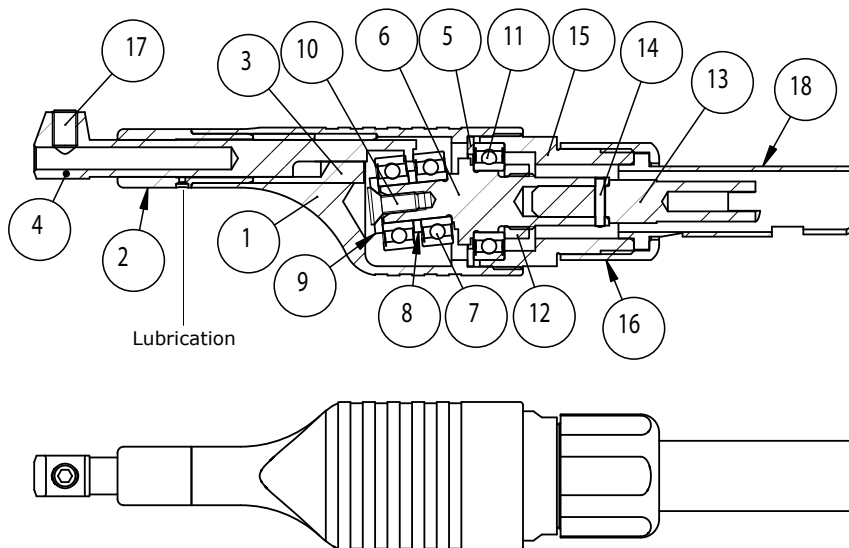

Pos.	Pcs.	REF	Description	
1	1	FMR-1	Housing	
2	1	FMR-73	Guide steering (front-piece)	
3	1	FMR-74	Guide steering (back-piece)	FMR-2/P
4	1	FMR-3	Tool-holder	
5	1	FMR-9	Washer	
6	1	FMR-45/46/50*	Main spindle	
7	2	44024	Ball bearing	
8	1	FMR-8	Spacer	
9	1	FMR-7	Bearing washer	
10	1	42039	Screw	
11	1	44022	Ball bearing	
12	1	FMR-54	Nut for main spindle	
13	1	FMR-12	Spindle drive mounting	
14	1	43016	Pin	
15	1	FMR-5	Back piece	
16	1	FMR-14	Spindel end cover	
17	1	42038	Locking Screw	
18	1	FMR-13	Conneting Sleeve	

*FMR-45 for Mini polishing/filing machine FMR/S5 (stroke length 0,5 mm).

*FMR-50 for Mini polishing/filing machine FMR/S10 (stroke length 1,0 mm).

*FMR-46 for Mini polishing/filing machine FMR/S15 (stroke length 1,5 mm).



Spare Parts

FMR/D...

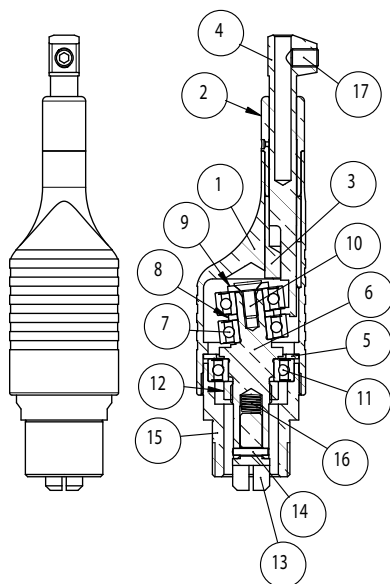

4

Pos.	Pcs.	REF	Description.
1	1	FMR-1	Housing
2	1	FMR-73**	Guide steering (front-piece)
3	1	FMR-74**	Guide steering (back-piece)
4	1	FMR-3	Tool-holder
5	1	FMR-9	Washer
6	1	FMR-45/46/50*	Main spindle
7	2	44024	Ball bearing
8	1	FMR-8	Spacer
9	1	FMR-7	Bearing washer
10	1	42039	Screw
11	1	44022	Ball bearing
12	1	FMR-54	Nut for main spindle
13	1	FMR-71	Spindle drive mounting
14	1	43016	Pin
15	1	FMR-5	Back piece
16	1	41009	Spring
17	1	42038	Locking Screw

*FMR-45 for Mini polishing/filing machine FMR/S5 (stroke length 0,5 mm).

*FMR-50 for Mini polishing/filing machine FMR/S10 (stroke length 1,0 mm).

*FMR-46 for Mini polishing/filing machine FMR/S15 (stroke length 1,5 mm).



FMR/G...

Spare parts

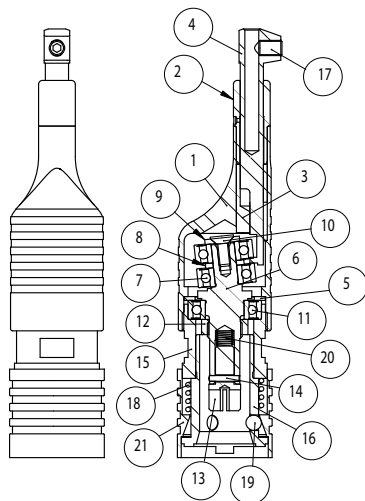

Pos.	Pcs.	REF	Description.
1	1	FMR-1	Housing
2	1	FMR-73**	Guide steering (front-piece)
3	1	FMR-74**	Guide steering (back-piece)
4	1	FMR-3	Tool-holder
5	1	FMR-9	Washer
6	1	FMR-45/46/50*	Main spindle
7	2	44024	Ball bearing
8	1	FMR-8	Spacer
9	1	FMR-7	Bearing washer
10	1	42039	Screw
11	1	44022	Ball bearing
12	1	FMR-54	Nut for main spindle
13	1	FMR-18	Spindle drive mounting
14	1	43016	Pin
15	1	FMR-60	Back piece
16	1	FMR-62	Inner Sleeve
17	1	42038	Locking Screw
18	1	FMR-63	Spring
19	3	44025	Steel Ball
20	1	41009	Spring
21	1	FMR-61	Outer Sleeve

*FMR-45 for Mini polishing/filing machine FMR/S5 (stroke length 0,5 mm).

*FMR-50 for Mini polishing/filing machine FMR/S10 (stroke length 1,0 mm).

*FMR-46 for Mini polishing/filing machine FMR/S15 (stroke length 1,5 mm).



Transverse mini polishing/filing machine

Info



This machine has a transverse movement for working on difficult surfaces, and is especially suitable on narrow shoulders. Variable stroke between 0-4 mm, that is easy to change by use of a hexagon key. The small and handy dimension improves control and effectiveness for polishing and finishing work. For the lowest possible vibration levels we recommend using light weight tools and tool-holders such as the THFS-1 and THPS-3.

All Diprofil Machines are delivered in a handy tool-box with the necessary accessories.



FMV/S

Flexible-shaft Drive - Slip Joint Connection



REF	€
FMV/S	548,59

The Diprofil Transverse Mini Polishing/Filing machine for flexible-shaft drive is available for connection to Slip-joint (FMV/S).

Technical data

Tool holder:	max Ø 3,6 mm
Stroke length:	Variable stroke 0-4 mm (measured 60 mm from the machine housing)
Speed:	max 12.000 rpm (at max 2 mm stroke length) recommended 5.000-11.000 rpm
Dimension:	Ø 24 mm
Weight:	235 g
Noise:	< 78 dB(A) at 12.000 rpm
Vibrations:	1,5 - 3,5 m/s ²

Frequency weighed hand/arm vibration, principally in accordance with ISO 28927-8. For further details, see diagram and other information in the corresponding Operation Guide.



Micro Motor Connection - Gesswein, Argofile & Uhandy

FMV/G

REF	€
FMV/G	548,59



The Diprofil Transverse Mini Polishing/Filing machine is available for Gesswein, Argofile and Uhandy connection (FMV/G).

Technical data

Tool holder:	max Ø 3,6 mm
Stroke length:	variable stroke 0-4 mm (measured 60 mm from the machine housing)
Speed:	max 12.000 rpm (at max 2 mm stroke length) recommended 5.000-11.000 rpm
Dimension:	Ø 24 mm
Weight:	210 g
Noise:	< 78 dB(A) at 12.000 rpm
Vibrations:	1,5 - 3,5 m/s ²

Frequency weighed hand/arm vibration, principally in accordance with ISO 28927-8. For further details, see diagram and other information in the corresponding Operation Guide.

4



FMV/D

Micro Motor Connection - Diprofil Motor type HPM-B1



REF	€
FMV/D	548,59

Dipromini Transverse polishing/filing machine with connection for Diprofil micro motor type HPM-B1 (FMV/D) which should be connected to, and controlled by, the DIPROFIL DPU-3, TPU-20 or corresponding power units.

Technical data

Tool holder:	max Ø 3,6 mm
Stroke length:	variable stroke 0-4 mm (measured 60 mm from the machine housing)
Speed:	max 12.000 rpm (at max 2 mm stroke length) recommended 5.000-11.000 rpm
Dimension:	Ø 24 mm
Weight:	195 g
Noise:	< 78 dB(A) at 12.000 rpm
Vibrations:	1,5 - 3,5 m/s ²

Frequency weighed hand/arm vibration, principally in accordance with ISO 28927-8. For further details, see diagram and other information in the corresponding Operation Guide.



Flexible-shaft Drive - Slip Joint Connection

FMV/S

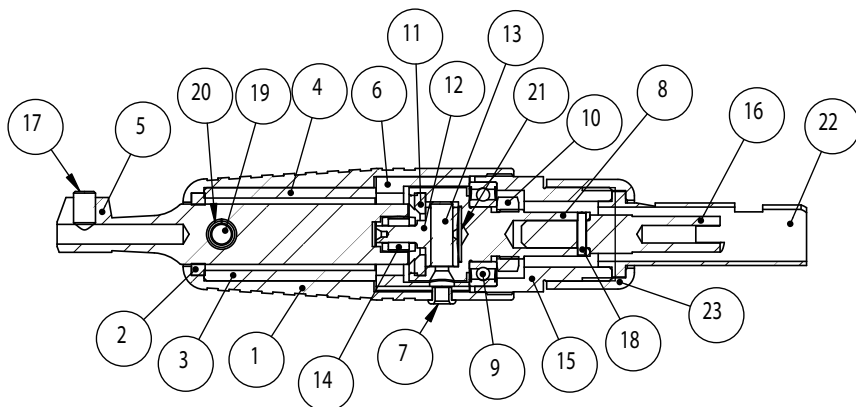

Pos.	Pcs.	REF	Description
1	1	FMV-1	Housing
2	1	FMT-8	Lubricating Felt
3	1	FMT-5	Upper guide steering
4	1	FMT-6	Lower guide steering
5	1	FMT-1	Tool Holder
6	1	FMV-5	Spacer
7	1	FMV-7	Bushing
8	1	FMV-2	Main spindle
9	1	44022	Ball bearing
10	1	FMR-5	4 Nut for main spindle
11	1	FMV-4	Eye nut
12	1	FMV-3	Crank pin
13	1	FMV-6	Adjusting screw
14	1	FMT-7	Crank bearing
15	1	FMR-5	Back piece
16	1	FMR-1	2 Spindle drive mounting
17	1	42038	Locking screw
18	1	43016	Pin
19	1	43021	Pin
20	1	44028	Bushing
21	1	41013	Cup spring
22	1	FMR-13	Connecting sleeve
23	1	FMR-14	Spindle end cover

4



FMV/G

Micro Motor Connection - Gesswein, Argofile & Uhandy

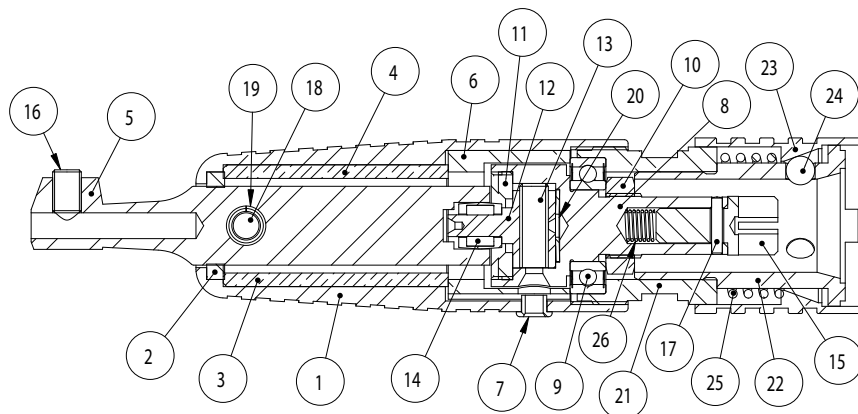

Pos.	Pcs.	REF	Description
1	1	FMV-1	Housing
2	1	FMT-8	Lubricating Felt
3	1	FMT-5	Upper guide steering
4	1	FMT-6	Lower guide steering
5	1	FMT-1	Tool Holder
6	1	FMV-5	Spacer
7	1	FMV-7	Bushing
8	1	FMV-2	Main spindle
9	1	44022	Ball bearing
10	1	FMR-54	Nut for main spindle
11	1	FMV-4	Eye nut
12	1	FMV-3	Crank pin
13	1	FMV-6	Adjusting screw
14	1	FMT-7	Crank bearing
15	1	FMR-18	Spindle drive mounting
16	1	42038	Locking screw
17	1	43016	Pin
18	1	43021	Pin
19	1	44028	Bushing
20	1	41013	Cup spring
21	1	FMR-60	Back piece
22	1	FMR-62	Inner sleeve
23	1	FMR-61	Outer sleeve
24	3	44025	Steel ball
25	1	FMR-63	Spring
26	1	41009	Spring



Micro Motor Connection - Diprofil Motor type HPM-B1

FMV/D

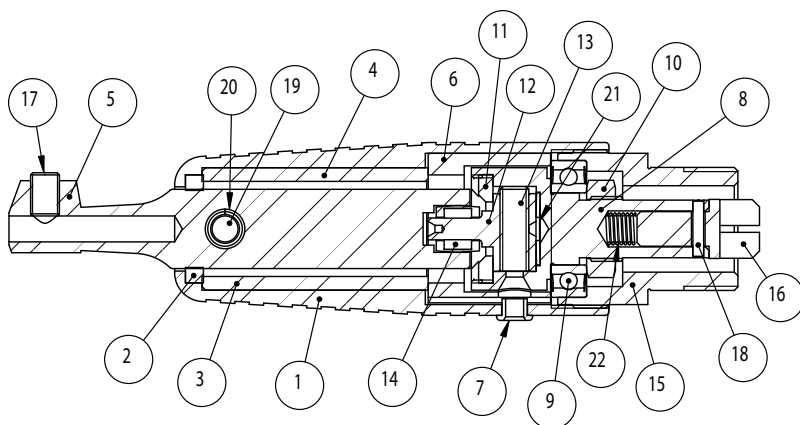

Pos.	Pcs.	REF	Description
1	1	FMV-1	Housing
2	1	FMT-8	Lubricating Felt
3	1	FMT-5	Upper guide steering
4	1	FMT-6	Lower guide steering
5	1	FMT-1	Tool Holder
6	1	FMV-5	Spacer
7	1	FMV-7	Bushing
8	1	FMV-2	Main spindle
9	1	44022	Ball bearing
10	1	FMR-54	Nut for main spindle
11	1	FMV-4	Eye nut
12	1	FMV-3	Crank pin
13	1	FMV-6	Adjusting screw
14	1	FMT-7	Crank bearing
15	1	FMR-5	Back piece
16	1	FMR-38	Spindle drive mounting
17	1	42038	Locking screw
18	1	43016	Pin
19	1	43021	Pin
20	1	44028	Bushing
21	1	41013	Cup spring
22	1	41009	Spring

4



Info

For efficient polishing and finishing operations



Rotary handpieces for efficient grinding, polishing and finishing operations with tools such as diamond and CBN pins, felt bobs and wood bobs.

All rotary hand pieces comes with the necessary tools and accessories.

C-HPM-BL1

Brushless Rotary Hand-piece



REF	€
C-HPM-BL1	1080,36

Micro-motor driven rotary hand-piece with brushless motor for use together with twin power unit TPU-20. Features a quick change design for both the collet and the tool and is supplied with 3,0 mm collet. Optional 2,35 mm collet available.

Technical data

Speed:	max. 40.000 rpm
Consumed power:	max. 230 W
Torque:	8,5N cm
Weight:	350 g
Dimensions:	L159 x Ø27 mm
Noise:	< 70 db(A) at 40.000 rpm
Vibrations:	< 2,5 m/s ²



Brushless Rotary Hand-piece

C-HPM-BL2

REF	€
C-HPM-BL2	1080,36



Micro-motor driven high speed rotary hand-piece with brushless motor for use together with twin power unit TPU-20. Features a quick change design for both the collet and the tool and is supplied with 3,0 mm collet. Optional 2,35 mm collet available.

Technical data

Speed:	max. 50.000 rpm
Consumed power:	max. 230 W
Torque:	7,6N cm
Weight:	350 g
Dimensions:	L159 x Ø27 mm
Noise:	< 70 db(A) at 50.000 rpm
Vibrations:	< 2,5 m/s ²

4

Rotary Hand-piece

C-HPM-B1

REF	€
C-HPM-B1	608,43



Micro-motor driven high speed rotary hand-piece with carbon brush motor for use together with power unit DPU-3 or twin power unit TPU-20. Features a quick change design for both the collet and the tool and is supplied with 3,0 mm collet. Optional 2,35 mm collet available.

Technical data

Speed:	max. 38.000 rpm
Consumed power:	100 W
Torque:	4,0N cm
Weight:	285 g
Dimensions:	L159 x Ø29,5 mm
Noise:	< 70 db(A) at 38.000 rpm
Vibrations:	< 2,5 m/s ²



DPU-3

Diprofil Power Unit



REF	€
DPU-3	500,26

This compact and ergonomic Power Unit is designed for use together with dedicated rotary hand-pieces and micro-motor driven reciprocating Diprofil polishing/filing machines with carbon brush motors. It has high torque and electrical feedback circuitry. Other features include continuously variable speed, forward / reverse switch and automatic overload protection. Supplied with foot control type DPU-3-FC for optional speed adjustment.

Technical data

Input:	AC 110/220 V at 50/60 Hz
Output:	DC 0 – 32 V, 1,2 A
Power:	max. 100 W
Weight Power unit:	1,7 kg
Dimensions Power unit:	W115 x D147 x H96 mm
Weight Foot control:	585 g



Micro-motor

HPM-B1

REF	€
HPM-B1	342,29



DC micro-motor adapted for Diprofil mini polishing/filing machines type FMR/D, FMV/D and rotary hand-piece type C-HPM-B1. For use together with power unit DPU-3 or twin power unit TPU-20.

Technical data

Speed:	max. 38.000 rpm
Consumed power:	100 W
Torque:	4,0N cm
Weight:	190 g
Dimensions:	L100 x Ø29,5 mm
Noise:	< 70 db(A) at 38.000 rpm
Vibrations:	< 2,5 m/s ²

4



TPU-20

Diprofil Twin Power Unit



REF	€
TPU-20-220V	1059,85

Twin power unit featuring dual control system for both brushless and carbon brush micro-motors (not simultaneously). Variable speed control by hand dial or the included foot control type TPU-20-FC. Supplied with hand-piece cradle and a convenient magnetic tool holder.

- Digital display showing the speed in rpm
- Maximum torque set mode
- Maximum speed set mode
- Built in handle for best portability
- Error code display function
- Foot control with auto-cruise speed function
- Self diagnosis system

Technical data

Input:	AC 200 ~ 240 V at 50/60 Hz
Output:	DC 0 – 32 V, 1,6 A, BLDC 0 – 32 V, 1,6 A
Power DC:	max. 185 W
Power BLDC:	max. 245 W
Weight Power unit:	2,9 kg
Dimensions Power unit:	W137 x D232 x H180 mm
Weight Foot control:	575 g

D/G

Adapter



REF	€
D/G	102,71

Adapter for connecting Urawa, Argofile and Gesswein front-pieces to the Diprofil micro-motors type HPM-BL1 and HPM-B1 (when using DC motor type HPM-B1 a specific shaft with item no. D/G-7 is also required).



Lubrication

MFB - MFA-K

REF	Description	€
MFB	Dipro-fog	393,88
MFA-K	Lubrication oil (0.5 l)	34,25



The Dipro-fog (MFB) package consists of air filter, regulator, manometer, and fog lubrication device, all in one, with tubing and Dipro-fog oil (MFA-K).

Technical data

Max primary pressure: 16 bar
 Max capacity at 7 bar: 1200 l/min
 Hose connection: 7 mm
 Secondary pressure: 0,5 - 10 bar

4

Quick Coupling

HSL-M

REF	Old DME REF	€
HSL-M	HDL	127,25



Each air-driven machine requires a quick coupling (HSL-M) as well as a fog lubricating device type Dipro-fog MFB to ensure efficient lubrication at all times. A 3-way hose connection and air hose is also available.



Info

Precision Diamond Files



Diprofil Diamond Files are made from carefully selected diamonds, precisely bonded to obtain the best physical properties for added strength and resistance to wear. Diamond files are excellent for use on carbide, hardened steel, glass, ceramics and other similar materials.

Other shapes, dimensions and grit sizes available upon request.

DLK ...

Diprofil®, Diamond machine files

Features:

- Grainsize according to FEPA
- Diamond D151 (coarse)

REF D151	Dimensions	€	Shape
DLK 11 151	10 x 2,5 mm	66,16	



Standard Machine Files

DLA...



Shape	Size (mm)	REF					
		Grit D64	€	Grit D151	€	Grit D181	€
	2x1	DLA-2x1S-D64	13,37	DLA-2x1S-D151	13,67	DLA-2x1S-D181	14,33
	3x1	DLA-3x1S-D64	14,02	DLA-3x1S-D151	14,33	DLA-3x1S-D181	15,03
	4x1	DLA-4x1S-D64	14,33	DLA-4x1S-D151	14,66	DLA-4x1S-D181	15,34
	4x2	DLA-4x2S-D64	15	DLA-4x2S-D151	15,34	DLA-4x2S-D181	16,17
	5x2	DLA-5x2S-D64	15,51	DLA-5x2S-D151	15,87	DLA-5x2S-D181	16,17
	Ø 1	DLA-1-D64	11,73	DLA-1-D151	11,99	DLA-1-D181	12,86
	Ø 2	DLA-2-D64	12,72	DLA-2-D151	13,01	DLA-2-D181	14,33
	Ø 3	DLA-3-D64	14,33	DLA-3-D151	14,66	DLA-3-D181	16,83
	Ø 4	DLA-4-D64	16,8	DLA-4-D151	17,18	DLA-4-D181	17,85
	R = 2,5x5	DLA-R2,5R5-D64	19,38	DLA-R2,5R5-D151	20,66	DLA-R2,5R5-D181	22,35

4

Safe Sided Machine Files

DLA...

Shape	Size (mm)	REF					
		Grit D64	€	Grit D151	€	Grit D181	€
	2x1	DLA-2x1-D64	17,62	DLA-2x1-D151	18,02	DLA-2x1-D181	18,02
	3x1	DLA-3x1-D64	17,86	DLA-3x1-D151	18,34	DLA-3x1-D181	19,01
	4x1	DLA-4x1-D64	18,25	DLA-4x1-D151	18,66	DLA-4x1-D181	19,5
	5x2	DLA-5x2-D64	19,07	DLA-5x2-D151	19,5	DLA-5x2-D181	20,14
	0,50x4			DLA-0,5x4-D151	22,65		
	1,00x4			DLA-1x4-D151	22,65		
	2x2x2	DLA-T2-D64	25,76	DLA-T2-D151	26,33	DLA-T2-D181	27,01
	3x3x3	DLA-T3-D64	27,06	DLA-T3-D151	27,67	DLA-T3-D181	28,32
	4x4x4	DLA-T4-D64	26,19	DLA-T4-D151	28	DLA-T4-D181	28,69



DLN...

Standard Hand Files

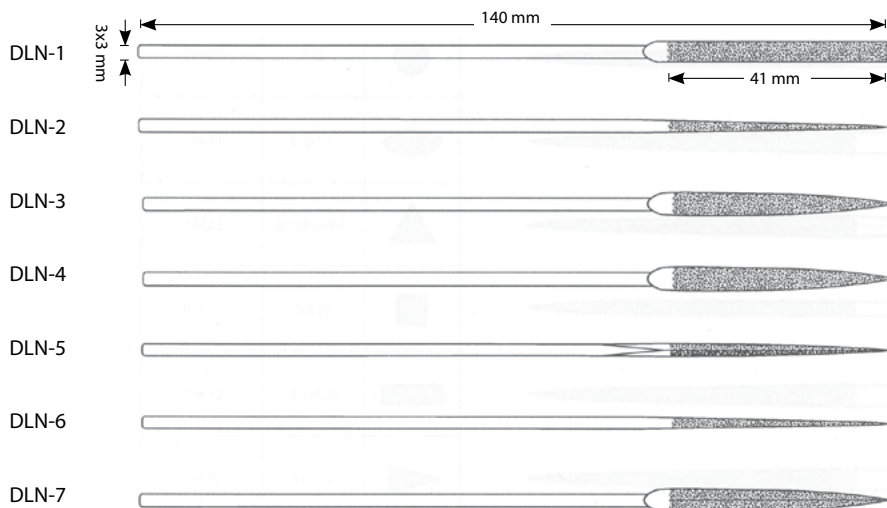

Shape	Size (mm)	REF			
		Grit D64	€	Grit D151	€
	4x1,3	DLN-1-D64	29,43	DLN-1-D151	30,09
	Ø 1,6	DLN-2-D64	29,43	DLN-2-D151	30,09
	4x1,8	DLN-3-D64	29,43	DLN-3-D151	30,09
	4x1,6	DLN-4-D64	29,43	DLN-4-D151	30,09
	3x3x3	DLN-5-D64	29,43	DLN-5-D151	30,09
	1,9x1,9	DLN-6-D64	29,43	DLN-6-D151	30,09
	4,1x1,5	DLN-7-D64	29,43	DLN-7-D151	30,09

KSD

Diamond Plated Rulers



Total length 250 mm, width 25mm, thickness 1,0 mm. Length of plated area 135 mm. Diamond plated all around.

Grit D64	€	REF	
		Grit D151	€
KSD-2035-D64	113,76	KSD-2035-D151	116,31



Diprofil®, Diamond hand files

DLN 100 ...

Features:

- Set of 7 diamond hand files, one of each DLN 1 to DLN 7

REF	Grain	€
DLN 100	D 64	•
DLN 100	D 151	186,82

DIPRO® precision diamond files

Info



4

Dipro Diamond Files are made from carefully selected diamonds, precisely bonded to obtain the best physical properties for added strength and resistance to wear. Diamond files are excellent for use on carbide, hardened steel, glass, ceramics and other similar materials.

Other shapes, dimensions and grit sizes available on request.



DLM...

Conical Machine Files

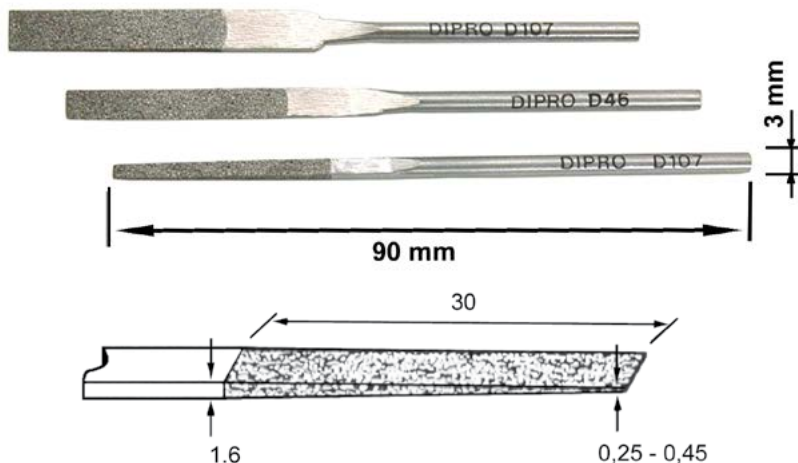

Standard Files

Shape	Size (mm)	REF							
		Grit D30	€	Grit D46	€	Grit D76	€	Grit D107	€
	2,5x1,6	DLM-1-D30	13,91	DLM-1-D46	13,91	DLM-1-D76	13,91	DLM-1-D107	13,91
	4x1,6	DLM-2-D30	13,91	DLM-2-D46	13,91	DLM-2-D76	13,91	DLM-2-D107	13,91
	6x1,6	DLM-3-D30	14,69	DLM-3-D46	14,69	DLM-3-D76	14,69	DLM-3-D107	14,69
	8x1,6	DLM-4-D30	17,07	DLM-4-D46	17,07	DLM-4-D76	17,46	DLM-4-D107	17,46

DLM-Set

Conical Machine Files Set



Sets consisting of 6 different DLM-files, DLM-1 through DLM-3 in the following grit sizes:

Grit sizes	REF	€
D46 + D107	DLM/1	85,2
D30 + D46	DLM-SET-F	85,2
D76 + D107	DLM-SET-M	85,2







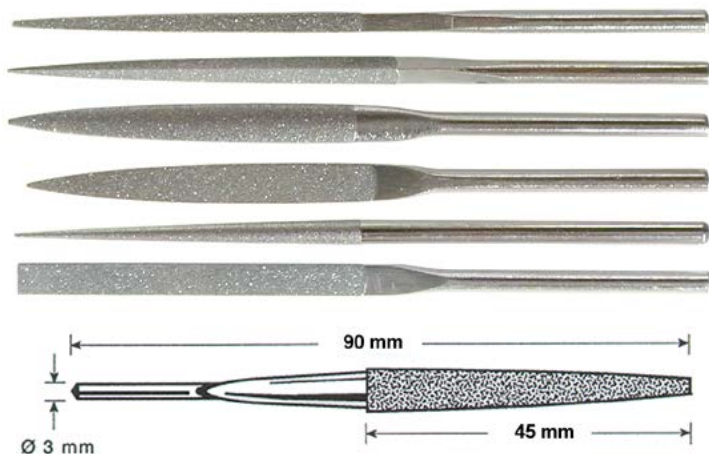

Machine Files

DBE...



4

Standard Files		REF					
Shape	Size (mm)	Grit D46	€	Grit D76	€	Grit D107	€
	4 x 2	DBE-1-D46	18,87	DBE-1-D76	18,87	DBE-1-D107	19,29
	ø3	DBE-2-D46	18,87	DBE-2-D76	19,29	DBE-2-D107	19,29
	5x2	DBE-3-D46	18,87	DBE-3-D76	18,87	DBE-3-D107	19,29
	5x2	DBE-4-D46	18,87	DBE-4-D76	18,87	DBE-4-D107	19,29
	3,5x3,5x3,5	DBE-5-D46	18,87	DBE-5-D76	18,87	DBE-5-D107	19,29
	2,5x2,5	DBE-6-D46	18,87	DBE-6-D76	18,87	DBE-6-D107	19,29

Machine Files Set

DBE-Set

Set consisting of the 6 different DBE-files in respective grit sizes.



REF	€
DBE-SET-D46	95,14
DBE-SET-D76	95,14
DBE-SET-D107	97,27



DLS...

Conical Hand Files

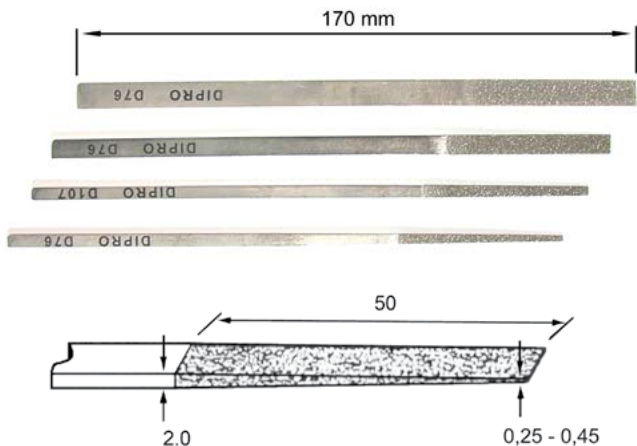

Standard Files

Shape	Size (mm)	REF							
		Grit D30	€	Grit D46	€	Grit D76	€	Grit D107	€
	4 / 2	DLS-1-D30	16,02	DLS-1-D46	16,02	DLS-1-D76	16,02	DLS-1-D107	16,02
	4 / 3	DLS-2-D30	16,54	DLS-2-D46	16,54	DLS-2-D76	16,54	DLS-2-D107	16,54
	6 / 6	DLS-3-D30	18,5	DLS-3-D46	18,5	DLS-3-D76	18,5	DLS-3-D107	18,5
	8 / 8	DLS-4-D30	19,81	DLS-4-D46	19,81	DLS-4-D76	19,81	DLS-4-D107	19,81

DLS-Set

Conical Hand Files Set



Sets consisting of 10 different DLS-handfiles.

Types	REF	€
DLS 2,3,4 in D46; DLS 1,2,3,4 in D76; DLS 2,3,4 in D107	DLS/1	174,07
DLS 1,2,3,4 in D30; DLS 1,2,3,4 in D46; DLS 1,2 in D76	DLS-SET-F	168,68



Hand Files

DBH...



Total file length approx 140 mm. Shank diameter 3 mm.

4

Shape	Size (mm)	REF					
		Grit D46	€	Grit D76	€	Grit D126	€
	6x1,5	DBH-1-D46	18,62	DBH-1-D76	18,62	DBH-1-D126	19,05
	ø3	DBH-2-D46	18,62	DBH-2-D76	18,62	DBH-2-D126	19,05
	5x2	DBH-3-D46	18,62	DBH-3-D76	18,62	DBH-3-D126	19,05
	5x2	DBH-4-D46	18,62	DBH-4-D76	18,62	DBH-4-D126	19,05
	3,5x3,5x3,5	DBH-5-D46	18,62	DBH-5-D76	18,62	DBH-5-D126	19,05
	2,5x2,5	DBH-6-D46	18,62	DBH-6-D76	18,62	DBH-6-D126	19,05
	6x2	DBH-7-D46	18,62	DBH-7-D76	18,62	DBH-7-D126	19,05
	5,4x1,5	DBH-8-D46	18,62	DBH-8-D76	18,62	DBH-8-D126	19,05
	1,7x6	DBH-9-D46	18,62	DBH-9-D76	18,62	DBH-9-D126	19,05
	6x1,5	DBH-10-D46	18,62	DBH-10-D76	18,62	DBH-10-D126	19,05

Hand Files Set

DBH-Set

Set consisting of the above 10 different DBH-handfiles in respective grit size.

REF	€
DBH-SET-D46	139,3
DBH-SET-D76	139,3
DBH-SET-D126	142,42





DLL...

Conical Hand Files



Total file length approx 140 mm. Shank diameter 3 mm.

Shape	Size (mm)	REF							
		Grit D30	€	Grit D46	€	Grit D76	€	Grit D107	€
	1,7x2	DLL-1-D30	19,05	DLL-1-D46	19,05	DLL-1-D76	19,05	DLL-1-D107	18,62
	1,7x4	DLL-2-D30	19,05	DLL-2-D46	19,05	DLL-2-D76	19,05	DLL-2-D107	18,62
	1,7x6	DLL-3-D30	19,05	DLL-3-D46	19,05	DLL-3-D76	19,05	DLL-3-D107	18,62
	ø3	DLL-4-D30	19,05						

DLL-Set

Conical Hand Files Set



Set consisting of 10 different DLL-handfiles.

Types	REF	€
DLL 1,2,3,4 in D30; DLL 1,2,3 in D46; DLL 1,2,3 in D76	DLL-SET	142,42
DLL-4-D30; DLL 1,2,3 in D46; DLL 1,2,3 in D76; DLL 1,2,3 in D107	DLL-SET-M	142,42



Hand Files

DLQ...



Shank diameter 4 mm.
200 mm

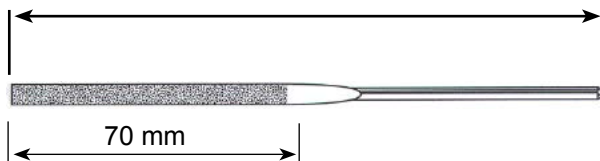

4

Standard Files		REF			
Shape	Size (mm)	Grit D46	€	Grit D126	€
	8,5x1,6	DLQ-1-D46	39,91	DLQ-1-D126	39,91
	ø4	DLQ-2-D46	39,91	DLQ-2-D126	39,91
	7x2,5	DLQ-3-D46	39,91	DLQ-3-D126	39,91
	3,5x3,5	DLQ-4-D46	39,91	DLQ-4-D126	39,91
	4,5 x4,5x4,5	DLQ-5-D46	39,91	DLQ-5-D126	39,91

Hand Files Set

DLQ-Set

Set consisting of the above 5 different DLQ-handfiles

REF	€
DLQ-SET-D46	182,33
DLQ-SET-D126	182,33







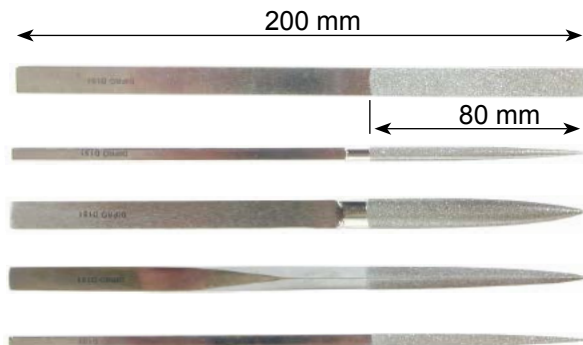

DLX...

Hand Files



Standard Files

Shape	Size (mm)	REF	
		Grit D151	€
	11 x 3,5	DLX-1-D151	47,39
	ø5	DLX-2-D151	47,39
	10,5x4,4	DLX-3-D151	47,39
	7,7x7,7x7,7	DLX-4-D151	47,39
	6,3x6,3	DLX-5-D151	47,39

DLX-Set

Hand Files Set



Set consisting of the above 5 different DLX-handfiles

REF	€
DLX-SET-D151	218,82



Diprofil®, Diamond machine files

DLE ...

Features:

- Grainsize according to FEPA
- Diamond D151 (coarse)
- Diamond D181 (very coarse)

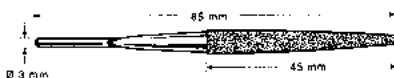

REF D151	€	REF D181	€	Dimensions	Shape
DLE 11 151	29,44	DLE 11 181	•	5 x 1 mm	
DLE 2 151	29,44	DLE 2 181	•	∅ 3 mm	
DLE 30 151	34,27	-		5 x 2 mm	
DLE 4 151	40,01	-		5 x 2 mm	
DLE 5 151	33,03	DLE 5 181	•	3,5 x 3,5 x 3,5 mm	
DLE 6 151	34,27	DLE 6 181	•	2,5 x 2,5 mm	
DLE 1 151	•	DLE 1 181	•	5 x 1 mm	
DLE 3 151	34,27	-		5 x 2 mm	

4

Diprofil®, Diamond machine files

DLF ...

Features:

- Grainsize according to FEPA
- Diamond D151 (coarse)
- Diamond D181 (very coarse)

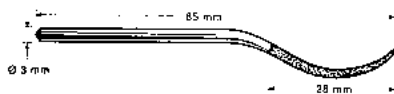

REF D151	€	REF D181	€	Dimensions	Shape
DLF 1 151	33,86	DLF 1 181	•	4,5 x 2,5 mm	
DLF 2 151	33,86	DLF 2 181	•	∅ 3 mm	
DLF 4 151	33,86	DLF 4 181	•	5 x 2,5 mm	
DLF 6 151	35,4	DLF 6 181	•	3 x 3 mm	







DLG ...

Diprofil®, Diamond hand files

Features:

- Grain size according to FEPA
- Diamond D 151 (coarse)
- Total length 140 mm
- Coating length 41 mm
- Shaft 2,2 x 2,2 mm

REF D151	Dimen- sions	€	Shape
DLG 1 151	10 X 3 mm	94,59	
DLG 2 151	Ø 6,5 mm	75,11	
DLG 3 151	12 X 4 mm	84,08	
DLG 4 151	9,5 x 9,5 x 9,5 mm	88,61	
DLG 5 151	5,5 x 5,5 x 5,5 mm	78,09	

DLG 100 ...

Diprofil®, Diamond hand files

REF	Grain	€
DLG 100	D 151	420,43

Features:

- Set of 5 diamond hand files, one of each DLG 1 to DLG 5



Diamond and CBN Rotary Tools

Info



4

Diprofil Rotary Diamond and CBN Tools are made from carefully selected quality diamonds and Cubic Boron Nitride, precisely bonded to obtain the best physical properties for added strength and resistance to wear.

Electroplated Diamond pins and wheels are excellent for general grinding applications in hard materials such as carbide, hardened steel and ceramics. They are normally used without cooling agent but in stationary applications, and when grinding in thin glass cooling is often required. Maximum temperature for Diamonds is 800° C.

Electroplated cylindrical CBN pins are excellent for general grinding applications in hardened steel. They are normally used without cooling agent but in stationary applications cooling is often required. Maximum temperature for CBN is 1200° C.

Recommended speeds

Recommend speed for dry cutting:

Diamond: 10 – 20 m/s

CBN: 15 – 30 m/s

Recommend speed for wet cutting:

Diamond: 15 – 30 m/s

CBN: 20 – 45 m/s

Cooling: Cooling normally enhances the lifetime of the tools. In addition it also generates a better surface. The risk for damage on thin or sharp edges of the grinding tool is reduced when using coolant.

Cooling is performed with an emulsion or grinding oil. For diamond tools an Emulsion is specially recommended and for CBN tools a mineral oil is preferable.



Info

Diamond and CBN Rotary Tools



Recommended speeds in RPM

Tool Ø (mm)	Peripheral speed (m/s)							
	10	20	25	30	35	40	45	50
2	95541	191083	238854	286624	334395	382166	429936	477707
3	63694	127389	159236	191083	222930	254777	286624	318471
4	47771	95541	119427	143312	167197	191083	214968	238854
5	38217	76433	95541	114650	133758	152866	171975	191083
6	31847	63694	79618	95541	111465	127389	143312	159236
7	27298	54595	68244	81893	95541	109190	122839	136488
8	23885	47771	59713	71656	83599	95541	107484	119427
9	21231	42463	53079	63694	74310	84926	95541	106157
10	19108	38217	47771	57325	66879	76433	85987	95541
12	15924	31847	39809	47771	55732	63694	71656	79618
14	13649	27298	34122	40946	47771	54595	61419	68244
16	11943	23885	29857	35828	41799	47771	53742	59713
18	10616	21231	26539	31847	37155	42463	47771	53079
20	9554	19108	23885	28662	33439	38217	42994	47771
22	8686	17371	21714	26057	30400	34742	39085	43428
24	7962	15924	19904	23885	27866	31847	35828	39809
26	7349	14699	18373	22048	25723	29397	33072	36747
28	6824	13649	17061	20473	23885	27298	30710	34122
30	6369	12739	15924	19108	22293	25478	28662	31847
35	5460	10919	13649	16379	19108	21838	24568	27298



Shank diameter: \varnothing 2,35 mm

	Shape	Dimensions	Grit Size	REF	€
	Cylinder	D 1,4, T 7, L 46	D 107	DT-86-HP	13,47
		D 1,9, T 5, L 46	D 151	DB-305-HP	22,97
		D 2,5, T 7, L 46	D 151	DT-100-HP	14,66
		D 2,6, T 3, L 46	D 151	DT-107-HP	15,97
	Ball	D 0,8, L 46	D 107	DB-1-2/0-HP	21,18
		D 1,3, L 46	D 107	DB-102-HP	21,18
		D 1,7, L 46	D 151	DB-104-HP	21,18
		D 1,9, L 46	D 151	DB-105-HP	21,9
		D 2,5, L 46	D 151	DB-108-HP	22,29
		D 3,0, L 41,3	D 151	DT-101-HP	20,36
		D 4,1, L 42,7	D 151	DT-119-HP	25,45
	Flame	D 1,3, T 4, R 18, L 46	D 151	DB-902A-HP	21,18
		D 1,6, T 7,5, R 45, L 46	D 151	DT-95B-HP	15,27
		D 2,4, T 7,5, R 30, L 46	D 151	DT-117-HP	15,97
		D 2,4, T 10, R 30, L 46	D 151	DT-510-HP	16,83
	Cone	D 5,1, a 27°, T 9,5, L 48,4	D 151	DT-93-HP	35,28
		D 7,3, a 60°, T 6, L 45,6	D 151	DT-236-HP	29,81
	Cone round	D 1,3, d 0,7, a 4°, T 9, L 46	D 151	DB-702-HP	17,75
		D 1,6, d 0,8, a 5°, T 9, L 46	D 151	DB-704-HP	18,61
		D 1,9, d 1,1, a 5°, T 9, L 46	D 151	DB-706-HP	19,91

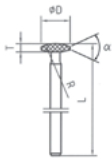
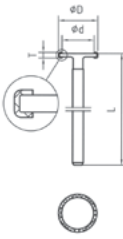
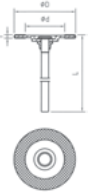
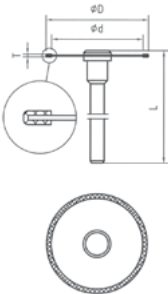

Shank diameter: Ø 2,35 mm

	Shape	Dimensions	Grit Size	REF	€
	Wheel	D 6,3, T 0,5, L 40	D 151	DT-129P-HP	31,99
	Wheel	D 9,3, a 16°, T 1,3, L 40,2	D 151	DT-109-HP	36
	Grinding wheel	D 8,7, d 7,0, T 1,3, L 40	D 151	DT-56P-HP	30,59
		D 9,0, d 7,0, T 0,6, L 40	D 151	DT-128P-HP	30,59
		D 12,9, d 9,5, T 1,4, L 45,4	D 151	DT-55P-HP	43,98
	Grinding wheel	D 20, d 12,75, T 1,0, L 48	D 151	DT-132P-HP	48,83
	Cutting wheel	D 15,0, d 13,0, T 0,6, L 48	D 151	DT-124P-HP	36,89
		D 18,0, d 16,0, T 0,6, L 48	D 151	DT-125P-HP	37,29
		D 20,0, d 18,0, T 0,6, L 48	D 151	DT-126P-HP	37,55
		D 22,0, d 20,0, T 0,6, L 48	D 151	DT-127P-HP	37,8





Shank diameter: \varnothing 3,0 mm

	Shape	Dimensions	Grit Size	REF	€
	Cylinder	D 0,8, T 4,0, B 7, L 46	D 107	D-0308L-H3	15,93
		D 1,0, T 4,0, B 8, L 46	D 107	D-0310L-H3	15,93
		D 1,5, T 4,0, B 10, L 46	D 107	D-0315L-H3	15,93
		D 2,0, T 5,0, B 14, L 46	D 151	D-0320L-H3	15,93
		D 2,0, T 5,0, B 14, L 46	D 64	D-0320L-H3-D64	16
		D 2,5, T 5,0, B 19, L 46	D 151	D-0325L-H3	16,64
		D 2,5, T 7,0, B 19, L 46	D 151	D-1325-H3	17,69
		D 3,0, T 5,0, B 19, L 46	D 151	D-0330L-H3	18,41
		D 3,0, T 5,0, B 19, L 46	D 64	D-0330L-H3-D64	18,49
	Cylinder	D 3,5, T 5,0, L 44	D 151	D-0335L-H3	24,44
		D 4,0, T 5,0, L 44	D 151	D-0340L-H3	25,16
		D 4,5, T 5,0, L 44	D 151	D-0345L-H3	26,54
		D 5,0, T 6,0, L 45	D 151	D-0350L-H3	29,39
		D 5,5, T 6,0, L 45	D 151	D-0352L-H3	24,54
		D 6,0, T 6,0, L 45	D 151	D-0354L-H3	26,07
		D 6,0, T 10, L 49	D 151	D-1354-H3	34,69
	Cylinder rounded	D 7,0, d 4,5, T 10, R 10, L 49	D 151	D-6258-H3	40,73

4

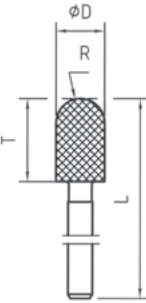

Shank diameter: Ø 3,0 mm

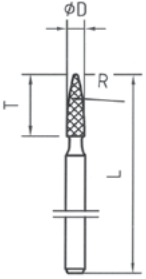
	Shape	Dimensions	Grit Size	REF	€
	Cylinder rounded end	D 6,0 T 10, R 3, L 49	D 151	D-6054-H3	37,15
	Ball	D 1,7, L 46	D 151	D-0116-H3	12,37
		D 1,7, L 46	D 64	D-0116-H3-D64	9,75
		D 2,1, L 46	D 151	D-0120-H3	12,47
		D 2,5, L 46	D 151	D-0124-H3	13,13
		D 3,0, L 46	D 151	D-0130-H3	14,18
		D 3,0, L 46	D 64	D-0130-H3-D64	14,23
		D 4,1, L 46	D 151	D-0140-H3	21,25
		D 5,0, L 46	D 151	D-0150-H3	29,39
	Flame	D 1,6, T 7,5, R 45, L 46	D 151	D-0916-H3	14,18
		D 1,6, T 10, R 45, L 46	D 151	D-0916L-H3	14,87
		D 1,6, T 10, R 45, L 46	D 64	D-0916L-H3-D64	14,94
		D 2,4, T 7,5, R 30, L 46	D 151	D-0924-H3	14,87
		D 2,4, T 10, R 30, L 46	D 151	D-0924L-H3	15,55
		D 2,4, T 10, R 30, L 46	D 64	D-0924L-H3-D64	15,62



Shank diameter: \varnothing 3,0 mm

	Shape	Dimensions	Grit Size	REF	€
	Cone	D 3,1, a 30°, T 5,0, L 46	D 151	D-5830-H3	20,53
		D 3,1, a 30°, T 5,0, L 46	D 64	D-5830-H3-D64	20,61
		D 8,0, a 90°, T 3,9, L 43,2	D 151	D-5562-H3	34,36
		D 8,0, a 60°, T 6,6, L 45,9	D 151	D-5662-H3	37,15
	Cone rounded end	D 1,3, d 0,7, a 4°, T 9, L 46	D 151	D-0712-H3	14,51
		D 1,6, d 0,8, a 5°, T 9, L 46	D 151	D-0716-H3	15,21
		D 1,9, d 1,1, a 5°, T 9, L 46	D 151	D-0720-H3	15,21
		D 1,9, d 1,1, a 5°, T 9, L 46	D 64	D-0720-H3-D64	15,28
	Cone flat end	D 1,6, d 0,9, a 4°, T 10, L 46	D 151	D-0516L-H3	15,21
		D 2,1, d 1,4, a 4°, T 10, L 46	D 151	D-0521L-H3	15,21
		D 2,1, d 1,4, a 4°, T 10, L 46	D 64	D-0521L-H3-D64	15,28
		D 2,6, d 1,75, a 4°, T 3, L 46	D 151	D-0526-H3	16,29
		D 7,0, d 2,0, a 30°, T 10, L 49	D 151	D-5858-H3	38,94
		D 8,0, d 1,4, a 45°, T 8,5, L 47,5	D 151	D-5756-H3	38,94
	Cone rounded	D 6,0, T 10, R 17, L 49	D 151	D-0954-H3	37,15
	Cone inverted	D 2,4, d 1,5, a 20°, T 3, L 46	D 151	D-0224-H3	15,55
		D 2,4, d 1,5, a 20°, T 3, L 46	D 64	D-0224-H3-D64	15,62
		D 6,5, d 3,5, a 15°, T 10, L 49	D 151	D-5456-H3	38,94
		D 8,0, d 3,0, a 90°, T 2,15, L 42	D 151	D-5062-H3	38,94



Shank diameter: Ø 3,0 mm

	Shape	Dimensions	Grit Size	REF	€
	Cone inverted, rounded end	D 6,0, d 3,5, a 20°, T 10, R 3, L 49	D 151	D-6154-H3	38,94
	Wheel	D 7,3, T 0,8, L 40	D 151	D-1525-H3	37,03
	Wheel	D 9,0, d 7, T 0,6, L 40	D 151	D-1018-H3	29,02
	Wheel	D 20, d 12,75, T 1,0, L 48	D 151	D-1539-H3	46,65
	Grinding wheel	D 17,2, d 14,6, T 2,4, L 48	D 151	D-1127-H3	46,65





Shank diameter: \varnothing 3,0 mm

	Shape	Dimensions	Grit Size	REF	€
	Grinding wheel	D 5,8, T 2,3, R 1, L 41	D 151	D-1422-H3	24,29
		D 9,8, T 3,4, R 1,5, L 42,2	D 151	D-1430-H3	31,83
	Cutting wheel	D 15,0, d 13,0, T 0,6, L 48	D 151	D-1021-H3	35,92
		D 18,0, d 16,0, T 0,6, L 48	D 151	D-1024-H3	36,31
		D 22,0, d 20,0, T 0,6, L 48	D 151	D-1031-H3	36,8
		D 36,0, d 34,0, T 1,0, L 48	D 151	D-1042-H3	62,24
	Grinding wheel	D 4,1, a 60°, T 1,5, L 40,2	D 151	D-1916-H3	20,2
		D 9,3, a 7,5°, T 1,3, L 41	D 151	D-1629-H3	27,1
	Grinding wheel	D 22,0, d 7,0, T 0,35, L 48	D 151	D-1231-H3	36,56
	Cone	D 0,6, R 0,3, a 5°, T 18, L 46	D 151	S-067	19,29



Diamond grinding pin sets - Shank diameter Ø 3,0 mm

	Description	Grit Size	REF	€
	<p>Set consisting of 1 each of the following Diamond points and pins in Grit size FEPA D 151.</p> <p>D-0116-H3 D-0130-H3 D-0320L-H3 D-0330L-H3 D-0720-H3 D-0521L-H3 D-5830-H3 D-0916L-H3 D-0924L-H3 D-0224-H3</p>	D 151	SET-10A-3	111,58
	<p>Set consisting of 1 each of the following Diamond points and pins in Grit size FEPA D 64.</p> <p>D-0116-H3-D64 D-0130-H3-D64 D-0320L-H3-D64 D-0330L-H3-D64 D-0720-H3-D64 D-0521L-H3-D64 D-5830-H3-D64 D-0916L-H3-D64 D-0924L-H3-D64 D-0224-H3-D64</p>	D 64	SET-10B-3	111,58
	<p>Set consisting of 1 each of the following Diamond points and pins in Grit size FEPA D 107 and D 151.</p> <p>D-0308L-H3 (D 107) D-0310L-H3 (D 107) D-0315L-H3 (D 107) D-0320L-H3 D-0325L-H3 D-0330L-H3 D-0116-H3 D-0120-H3 D-0124-H3 D-0130-H3</p>	D 107 / D 151	SET-20A-3	111,58



Shank diameter: Ø 6,0 mm

	Shape	Dimensions	Grit Size	REF	€
	Cylinder	D 6, T 8, L 60	D 151	D-0354L-H6	30,42
		D 7, T 8, L 60	D 151	D-0358L-H6	34,77
		D 8, T 8, L 60	D 151	D-0362L-H6	35,53
		D 10, T 10, L 60	D 151	D-0370L-H6	36,8
		D 12, T 10, L 60	D 151	D-0374L-H6	38,22
		D 15, T 10, L 60	D 151	D-0380L-H6	40,27



Info

Original diprofil precision CBN tools



Diprofil CBN Rotary Tools are made from carefully selected CBN (Cubic Boron Nitride), precisely bonded to obtain the best physical properties for added strength and resistance to wear. CBN tools are excellent for use on Tool Steels, Stainless Steels and Cast Iron.

Other shapes, dimensions and grit sizes available upon request.



Shank diameter: \varnothing 3,0 mm

	Shape	Dimensions	Grit Size	REF	€
	Cylinder	D 0,8, T 4,0, B 7, L 46	B 107	B-0308L-H3	13,03
		D 1,0, T 4,0, B 8, L 46	B 107	B-0310L-H3	13,03
		D 1,5, T 4,0, B 10, L 46	B 107	B-0315L-H3	13,39
		D 2,0, T 5,0, B 14, L 46	B 151	B-0320L-H3	13,39
		D 2,5, T 5,0, B 19, L 46	B 151	B-0325L-H3	14,04
		D 3,0, T 5,0, B 19, L 46	B 151	B-0330L-H3	15,49
	Cylinder	D 3,5, T 5,0, L 44	B 151	B-0335L-H3	20,46
		D 4,0, T 5,0, L 44	B 151	B-0340L-H3	21,14
		D 4,5, T 5,0, L 44	B 151	B-0345L-H3	22,45
		D 5,0, T 6,0, L 45	B 151	B-0350L-H3	24,68
		D 5,5, T 6,0, L 45	B 151	B-0352L-H3	26,4
		D 6,0, T 6,0, L 45	B 151	B-0354L-H3	27,95

4

Shank diameter: \varnothing 6,0 mm

	Shape	Dimensions	Grit Size	REF	€
	Cylinder	D 6, T 8, L 60	B 151	B-0354L-H6	31,24
		D 7, T 8, L 60	B 151	B-0358L-H6	35,7
		D 8, T 8, L 60	B 151	B-0362L-H6	36,49
		D 10, T 10, L 60	B 151	B-0370L-H6	37,8
		D 12, T 10, L 60	B 151	B-0374L-H6	39,25
		D 15, T 10, L 60	B 151	B-0380L-H6	41,36



DTP...

Precision Diamond Taper Pins

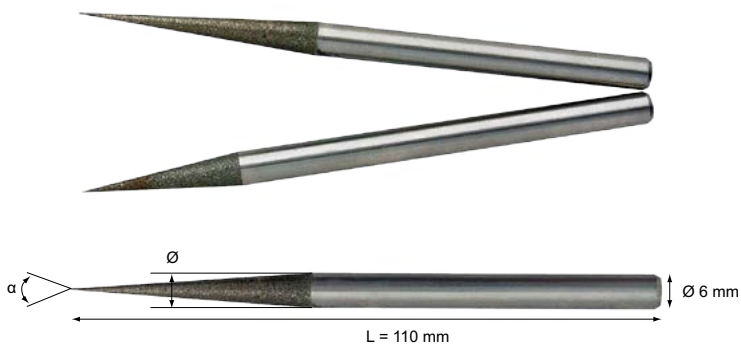

Ideal for grinding and polishing of carbide drawing dies for the wire and tube industries. All tools have \varnothing 6 mm shank.

Angle = α	Diameter = \varnothing	Grit Size	REF	€
8°	6 mm	D 76	DTP-86-D76	52,25
8°	6 mm	D 91	DTP-86-D91	52,25
8°	10 mm	D 76	DTP-810-D76	64,06
8°	10 mm	D 91	DTP-810-D91	64,06
12°	6 mm	D 76	DTP-126-D76	48,44
12°	6 mm	D 91	DTP-126-D91	48,44
12°	10 mm	D 76	DTP-1210-D76	62,75
12°	10 mm	D 91	DTP-1210-D91	62,75

All types are also available as blanks for polishing and final finishing with Diamond Compound.

Angle = α	Diameter = \varnothing	Grit Size	REF	€
8°	6 mm	n/a	DTP-86	32,69
8°	10 mm	n/a	DTP-810	42,4
12°	6 mm	n/a	DTP-126	29,54
12°	10 mm	n/a	DTP-1210	41,61



Diamond Cutting Discs

ASEA...



Other dimensions and grit sizes available upon request

Dimensions (Ø x Width x Bore Ø)	Grit Size	REF	€
20 x 0,4 x 2,5	D107	ASEA-20/040	32,82
20 x 0,6 x 2,5	D151	ASEA-20/060	32,82
20 x 0,8 x 2,5	D151	ASEA-20/080	32,82
20 x 1,0 x 2,5	D151	ASEA-20/100	32,82
22 x 0,6 x 2,5	D151	ASEA-22/060	36,76
25 x 0,8 x 2,5	D151	ASEA-25/080	39,65
30 x 0,8 x 6	D151	ASEA-30/080	42,26
36 x 1,0 x 2,5	D151	ASEA-36/100	45,15

4

Mandrels for Diamond Cutting Discs

MLD/P - MLE/P



Hardened stainless mandrel shanks

Type	REF	€
Shank Ø 2,35 mm, Flange Ø 5 mm, Screw M2,5	MLD/P	17,59
Shank Ø 3,0 mm, Flange Ø 6 mm, Screw M2,5	MLE/P	17,59



Info

Polishing, Lapping & Honing Tools



Diprofil offer a wide range of Honing and Lapping Tools for all kinds of polishing and super finishing applications. All Lapping Tools are excellent as carriers for the Diprofil Diamond Compound.

WB-...

Wood Bobs Ø 3 mm

Ø 3,0 x 30 mm	Dimension Ø x T (mm)	Hard Wood	€	Soft Wood	€
	Ø 20,0 x 30,0	WB-2030/H	•	WB-2030/S	•
	Ø 15,0 x 25,0	WB-1525/H	•	WB-1525/S	•
	Ø 10,0 x 20,0	WB-1020/H	•	WB-1020/S	•
	Ø 6,0 x 15,0	WB-615/H	•	WB-615/S	•
	Ø 10,0	WB-10/H	•	WB-10/S	•
	Ø 10,0 x 30,0	WB-1030/H	•	WB-1030/S	•



Polishing Tools on plastic shoes

MS... - VF... - FF...

Excellent for delicate polishing applications together with Polishing-/Filing machines and the Toggle rod type TR-3140.

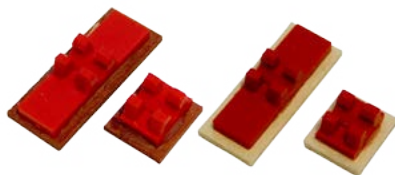

Type	Dimension (mm)	Quantity	REF	€
Brass	15x13x1,5	1 pc	MS-15x13	13,39
Brass	33x13x1,5	1 pc	MS-33x13	14,04
Fibre	15x13x1,5	1 pc	VF-15x13	12,86
Fibre	33x13x1,5	1 pc	VF-33x13	13,39
Felt	15x13x2	1 pc	FF-15x13	12,86
Felt	33x13x2	1 pc	FF-33x13	13,39

4

DI-PRO Polishing-kit

FX-PK

The low weight of the tools makes them especially suitable for use with the low-vibrating Di-Pro Polishing-/Filing machines. Using the tools included in this kit ensures that potentially harmful vibrations are kept at a minimum level. Also reduces the need for adding and removing counterweight inserts as all the included tools are within the same weight span.

Kit includes the following items:

- 1 Toggle rod TR-3140
- 2 pcs of MS-15x13
- 1 pc of MS-33x13
- 2 pcs of FF-15x13
- 1 pc of FF-33x13
- 2 pcs of VF-15x13
- 1 pc of VF-33x13
- 1 pc of PS-129
- 1 pc of PS-309



DI-PRO

REF	€
FX-PK	255,71



LRP... - LRB...

Polishing, Lapping & Honing Tools



Rotating tools for use together with Diamond Compound in various lapping and polishing applications.

Plastic

Brass

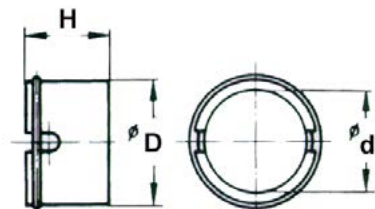
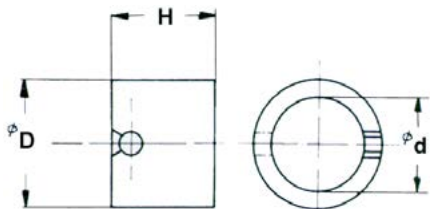

Material	Type	ø D (mm)	ø d (mm)	Height (mm)	Quantity	REF	€
Plastic	8	9	6	6	10 pcs	LRP-8	34,65
Plastic	12	13	10	8	20 pcs	LRP-12	79,94
Plastic	20	21	17	14	10 pcs	LRP-20	87,69
Brass	8	8	6	6	10 pcs	LRB-8	72,47
Brass	12	12	10	8	20 pcs	LRB-12	176,68
Brass	20	20	17	14	10 pcs	LRB-20	193,88

LLC...

Honing tools

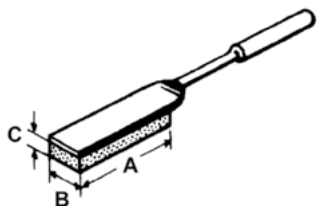

Rectangular honing tool on shank diameter 3,0 mm

Type	Dimensions (AxBxC)	REF	€
India Grit 280 Hard	18 x 7 x 2 mm	LLC-2A3	13,79



Mandrels

M...

Mandrels for use together with Lapping rings. Snaps on and keeps rings flat against the work surface.

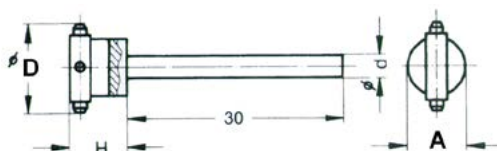

For use with:	Ø D (mm)	Shank Ø d (mm)	H (mm)	A (mm)	REF	€
Type 8 rings	8	3,0	6	5	M-8/3	27,04
Type 12 rings	12	3,0	7,5	8	M-12/3	30,71
Type 20 rings	20	3,0	7,5	8	M-20/3	39,65
Type 20 rings	20	6,0	11	9	M-20/6	54,61

4

Lapping tools

LLB...

Rectangular lapping tools on shank diameter 3,0 mm

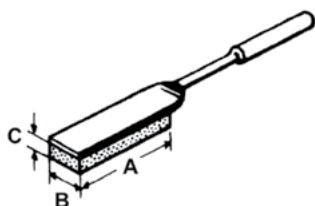

Type	Dimensions (AxBxC)	REF	€
Cast Iron	18 x 7 x 1 mm	LLB-1A	19,69
Copper	18 x 7 x 1 mm	LLB-2A	15,23
Fibre	18 x 7 x 1,5 mm	LLB-4A	11,15
Balsa Wood	18 x 7 x 1,5 mm	LLB-5A	13,26
Felt	18 x 7 x 3 mm	LLB-7A	11,15



Info

Polishing, Lapping & Honing Tools

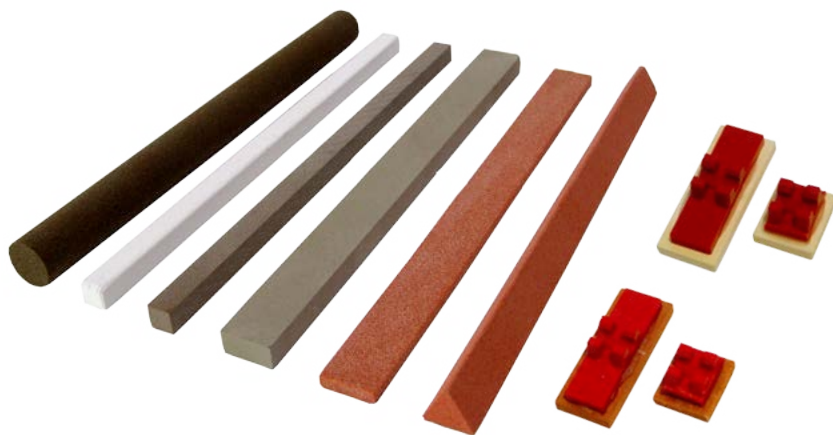



Polishing Stones on plastic shoes

EDM... - MOL...

Excellent for delicate stoning applications together with Polishing-/Filing machines and the Toggle rod type TR-3140.

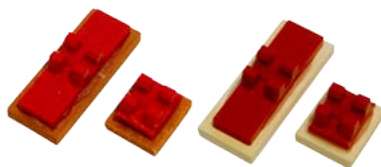

Type	Dimension (mm)	Grit size	Quantity	REF	€
EDM	15x13x3	G120	1 pc	EDM-15-120	14,31
EDM	33x13x3	G120	1 pc	EDM-33-120	14,84
EDM	15x13x3	G180	1 pc	EDM-15-180	14,31
EDM	33x13x3	G180	1 pc	EDM-33-180	14,84
EDM	15x13x3	G320	1 pc	EDM-15-320	14,57
EDM	33x13x3	G320	1 pc	EDM-33-320	15,09
MOL	15x13x3	G400	1 pc	MOL-15-400	14,57
MOL	33x13x3	G400	1 pc	MOL-33-400	15,09
MOL	15x13x3	G600	1 pc	MOL-15-600	14,84
MOL	33x13x3	G600	1 pc	MOL-33-600	15,62

4

Toggle Rod

TR-3140

Toggle rod for plastic shoes. Can easily be bent to an angle if required.

Shank Ø 3,5 mm
Length 140 mm



REF	€
TR-3140	81,12



FX-SK

DI-PRO Stoning-kit



Di-PRO

The low weight of the tools makes them especially suitable for use with the low-vibrating Di-Pro Polishing-/Filing machines. Using the tools included in this kit ensures that potentially harmful vibrations are kept at a minimum level. Also reduces the need for adding and removing counterweight inserts as all the included tools are within the same weight span.

The kit includes the following items:

- 1 Toggle rod TR-3140
- 2 pcs of EDM-15-120
- 1 pc of EDM-33-120
- 2 pcs of EDM-15-180
- 1 pc of EDM-33-180
- 2 pcs of EDM-15-320
- 1 pc of EDM-33-320
- 2 pcs of MOL-15-400
- 1 pc of MOL-33-400
- 2 pcs of MOL-15-600
- 1 pcs of MOL-33-600

REF	€
FX-SK	282,22



Tool Holders

Info



4

Tool holders for polishing stones, super stones, super grinders and lapping ribs.



THFS-1

Super Stone Holder



Tool-holder made of hardened steel for use together with ceramic fibre stones (Super stones) and lapping-/polishing tools with a thickness of 1 mm.

Shank Ø: 3,0 mm
Shank length: 18 mm
Total length: 31,5 mm
Width: 8 mm
Weight: 4,3 g

REF	€
THFS-1	25,74

THPS-3

Universal tool holder



Tool-holder made of hardened steel for use together with polishing stones and lapping-/polishing tools with a thickness of 3 mm.

Shank Ø: 3,0 mm
Shank length: 18 mm
Total length: 31,5 mm
Width: 8 mm
Weight: 3,9 g

REF	€
THPS-3	29,41



Universal tool holder

FMR/VH

Tool holder for Super Stones, Super Grinders and Polishing Stones to be used together with the Diprofil Polishing/Filing Machines. Stainless hardened shank \varnothing 3,0 mm. Shank length approx. 35 mm. Maximum tool thickness 6 mm.



REF	€
FMR/VH	40,03

4

Tool holder

QEA/3

Tool holder for use in the Diprofil Polishing/Filing Machines together with Polishing Stones and Lapping Ribs with maximum cross section area 13x13 mm or \varnothing 13 mm. Shank \varnothing 3,0 mm.



REF	€
QEA/3	28,89



QEA/6

Tool holder



Tool holder for use in the Diprofil Polishing/ Filing Machines together with Polishing Stones and Lapping Ribs with maximum cross section area 13x13 mm or Ø 13 mm. Shank Ø 6,0 mm.

REF	€
QEA/6	34,91

VEA

Tool holder



Hinged Tool holder for Polishing Stones and Lapping Ribs with maximum cross section area 11x13 mm or Ø 13 mm. Shank Ø 3,0 mm.

REF	€
VEA	20,35



Plastic shoes / Tool holders

PS...

Plain plastic shoes for making your own special tools adapted to the specific application.

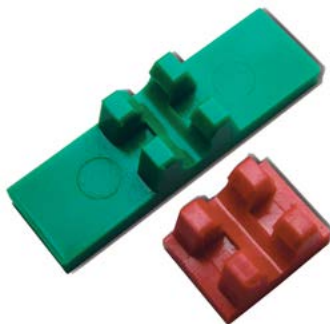

Dimension (mm)	Quantity	REF	€
12x9x2	10 pcs	PS-129	5,78
30x9x2	10 pcs	PS-309	6,44

4

Toggle Rod

TR-3140

Toggle rod for plastic shoes. Can easily be bent to an angle if required.

Shank Ø 3,5 mm
Length 140 mm



REF	€
TR-3140	81,12



Info

Precision Steel Files



Diprofil precision steel files for use in soft and semi-hard steel as well as other materials of low to medium hardness.



Steel Files

STL...

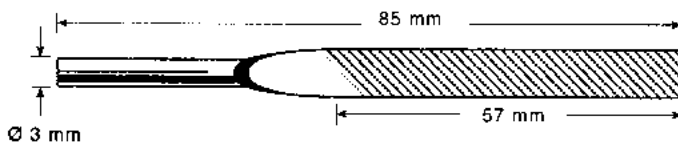

Shape	Size (mm)	REF			
		Medium Cut -00	€	Fine Cut -1	€
	5x1,5	STL-1-00/P	67,54*	STL-1-1/P	68,05*
	Ø3	STL-2-00/P	73,19*	STL-2-1/P	73,7*
	5x2	STL-3-00/P	92,18*	STL-3-1/P	92,69*
	5x2	STL-4-00/P	87,31*	STL-4-1/P	87,82*
	3,5x3,5x3,5	STL-5-00/P	86,53*	STL-5-1/P	87,05*
	2,5x2,5	STL-6-00/P	79,85*	STL-6-1/P	80,37*

*5 pieces

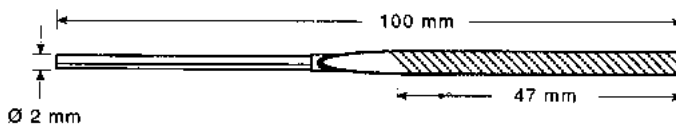

Shape	Size (mm)	REF			
		Medium Cut -00	€	Fine Cut -1	€
	3,3x1	STL-21-00/P	68,55*	STL-21-1/P	69,07*
	Ø2	STL-22-00/P	68,55*	STL-22-1/P	69,07*
	3,2x1,1	STL-23-00/P	73,95*	STL-23-1/P	74,47*
	3x1,3	STL-24-00/P	80,12*	STL-24-1/P	80,63*
	2,2x2,2x2,2	STL-25-00/P	77,29*	STL-25-1/P	77,81*
	1,7x1,7	STL-26-00/P	77,29*	STL-26-1/P	77,81*

*5 pieces



STL...

Steel Files

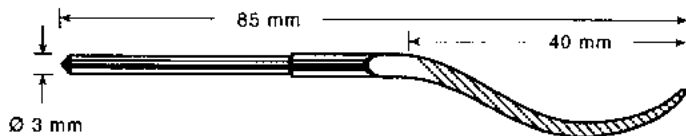

Shape	Size (mm)	REF			
		Medium Cut -00	€	Fine Cut -1	€
	4x2	STL-11-00/P	19,77	STL-11-1/P	20,29
	Ø3	STL-12-00/P	22,34	STL-12-1/P	23,11
	4,7x2,5	STL-14-00/P	38,78	STL-14-1/P	39,29
	3x3	STL-16-00/P	24,65	STL-16-1/P	25,17

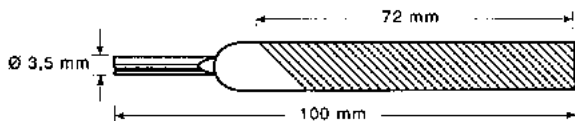

Shape	Size (mm)	REF			
		Medium Cut -00	€	Fine Cut -1	€
	10x2,5	STL-101-00/P	19,77	STL-101-1/P	20,02

DME
Every step of the way
DIPROFIL®

Sets



4

DIPROFIL® and Di-Pro® are registered trademarks of Diamantprodukt AB.

07/10/2013



Info

Sets

	REF	€	Includes	Description
	FXP-SET-L	3338,09	FXP	See page 5
			C-HPM-BL-2	See page 29
			TPU-20-220V	See page 32
	FXP-SET-M	2619,12	FXP	See page 5
			TPU-20-220V	See page 32
	FXP-SET-S	2182,59	FXP	See page 5
			DPU-3	See page 30
	FXM-SET-L	3492,15	FXM	See page 5
			C-HPM-BL-2	See page 29
			TPU-20-220V	See page 32
	FXM-SET-M	2773,18	FXM	See page 5
			TPU-20-220V	See page 32
	FXM-SET-S	2336,66	FXM	See page 5
			DPU-3	See page 30
	FMV-SET-S	1001,43	FMV/D	See page 22
			HBM-B1	See page 31
			DPU-3	See page 30
	FMR-SET-5S	898,72	FMR/D5	See page 17
			HBM-B1	See page 31
			DPU-3	See page 30
	FMR-SET-10S	898,72	FMR/D10	See page 17
			HBM-B1	See page 31
			DPU-3	See page 30
	FMR-SET-15S	898,72	FMR/D15	See page 17
			HBM-B1	See page 31
			DPU-3	See page 30
	DPU-SET-S	641,94	DPU-3	See page 30
			C-HPM-B1	See page 29



Other Files

4



N ...

Swiss needle-point files



cut 1 = coarse - cut 2 = middle - cut 3 = fine

Total length: 160 mm
Shank-Ø: 3 mm
Material: Steel

	REF	Cut	€	Cut arrangement
	N 01	1	5,88	
	N 01	2	5,88	
	N 01	3	6,49	
	N 02	1	6,86	
	N 02	2	6,86	
	N 02	3	7,22	
	N 03	1	6,86	
	N 03	2	6,86	
	N 03	3	6,86	
	N 05	1	6,86	
	N 05	2	6,86	
	N 05	3	.	
	N 07	1	6,13	
	N 07	2	6,13	
	N 07	3	6,86	
	N 08	1	6,49	
	N 08	2	6,49	
	N 08	3	6,49	
	N 10	1	5,74	
	N 10	2	6,49	
	N 10	3	7,08	
	N 11	1	6,49	
	N 11	2	6,49	
	N 11	3	6,49	

H 400 / H 500

Needle-point files handles



REF	€
H 400	2,3



REF	€
H 500	19,14

H 400 -
Material: Plastics. L = 80 mm.
Clamping range: 2,3 to 4 mm

H 500 -
Material: Plastics with pressure rotary clamp-
ing device. L = 96 mm.
Clamping range: 2 to 3,1 mm

Vallorbe®, Riffler files

R ...

Total length: 150 mm
Material: Steel



cut 1 = coarse - cut 2 = middle - cut 3 = fine

	REF	Cut	€	Cut arrangement
	R 00	2	13,32	
	R 00	4	16,13	
	R 01	2	14,05	
	R 01	4	16,13	
	R 02	2	13,32	
	R 02	4	16,13	
	R 10	2	•	
	R 10	4	17,93	
	R 11	2	14,7	
	R 11	4	17,93	
	R 12	2	14,7	
	R 12	4	17,93	
	R 13	2	14,7	
	R 13	4	17,93	
	R 14	2	14,7	
	R 14	4	17,93	
	R 15	2	14,7	
	R 15	4	17,93	
	R 16	2	14,7	
	R 16	4	17,93	
	R 17	2	14,7	
	R 17	4	17,93	
	R 18	2	14,7	
	R 18	4	17,93	
	R 20	2	14,7	
	R 20	4	20,69	
	R 30	2	14,7	
	R 30	4	17,93	
	R 31	2	13,32	
	R 31	4	16,13	

4



R ...

Vallorbe®, Riffler files



cut 1 = coarse - cut 2 = middle - cut 3 = fine

Total length: 150 mm
Material: Steel

Vallorbe®, Riffler files

R ...

Total length: 150 mm
Material: Steel



cut 1 = coarse - cut 2 = middle - cut 3 = fine

	REF	Cut	€	Cut arrangement
	R 74	2	14,7	
	R 74	4	17,93	
	R 80	2	13,32	
	R 80	4	16,13	
	R 81	2	13,32	
	R 81	4	16,13	
	R 82	2	13,32	
	R 82	4	16,13	
	R 83	2	13,32	
	R 83	4	16,13	
	R 84	2	13,32	
	R 84	4	16,13	
	R 85	2	13,32	
	R 85	4	16,13	
	R 86	2	13,32	
	R 86	4	16,13	
	R 87	2	13,32	
	R 87	4	16,13	
	R 88	2	13,32	
	R 88	4	16,13	
	R 96	2	14,7	
	R 96	4	19,36	

4

Riffler files handles

R 700

Material: Plastics

REF	€
R 700	8,53



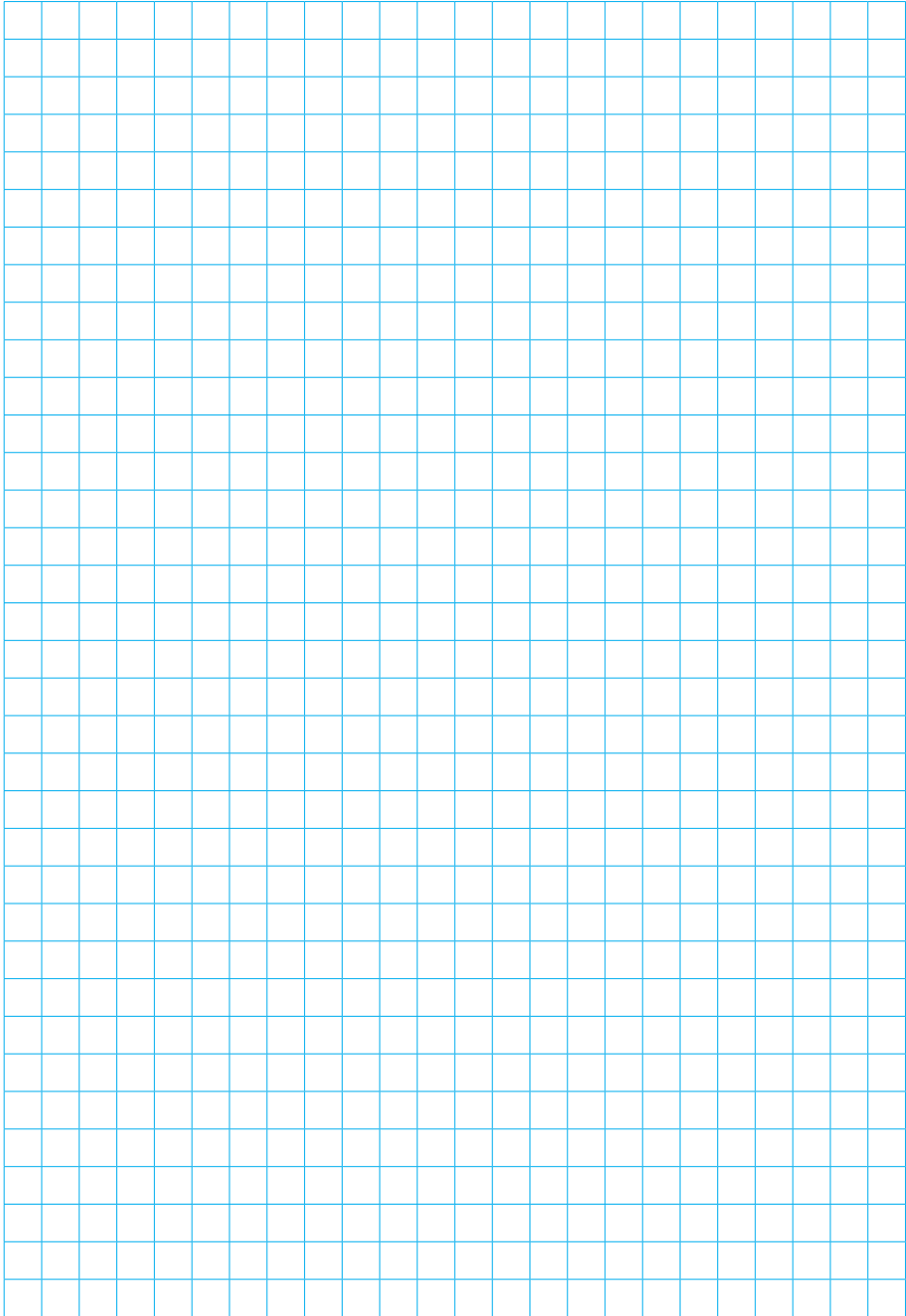



Files for hand operated filing machines

MF 310 ...

- Total length: 80 mm
- Coating length: 55 mm
- Shank Ø: 3 mm
- Material: Steel

	REF		€	Coating
	MF 3101	5	55,21	
	MF 3102	5	55,21	
	MF 3103	5	55,21	
	MF 3104	5	55,21	
	MF 3105	5	55,21	

4



F 21 ...

Diamond needle-point files, electro-bonded

- D91
- D126
- D181

Features:

- Total length: 140 mm
- Shank- Ø: 3 mm
- Coating length: 70 mm

	REF	Grain	€	Coating
	F 2112	D 91	12,71	
	F 2112	D 126	12,71	
	F 2112	D 181	12,71	
	F 2122	D 91	12,08	
	F 2122	D 126	12,08	
	F 2122	D 181	12,08	
	F 2132	D 91	12,08	
	F 2132	D 126	12,08	
	F 2132	D 181	12,08	
	F 2142	D 91	12,08	
	F 2142	D 126	12,08	
	F 2142	D 181	12,08	
	F 2152	D 91	12,08	
	F 2152	D 126	12,08	
	F 2152	D 181	12,08	
	F 2162	D 91	12,08	
	F 2162	D 126	12,08	
	F 2162	D 181	12,08	
	F 2172	D 91	12,08	
	F 2172	D 126	12,08	
	F 2172	D 181	12,08	
	F 2182	D 91	12,08	
	F 2182	D 126	12,08	
	F 2182	D 181	12,08	
	F 2192	D 91	12,08	
	F 2192	D 126	12,08	
	F 2192	D 181	12,08	
	F 2102	D 91	16,57	
	F 2102	D 126	16,57	
	F 2102	D 181	18,8	



Diamond needle-point files, electro-bonded

F 2111 - F 2116

Includes:

- F 2111: Set of 5 diamond hand files, one of each F 2112 - F 2132 - F 2142 - F 2152 - F 2162
- F 2116: Set of 6 diamond hand files, one of each F 2112 - F 2122 - F 2132 - F 2142 - F 2152 - F 2162



■ D91

■ D126

■ D181

REF	Grain	€
F 2111	D 91	54,08
F 2111	D 126	54,08
F 2111	D 181	54,08

REF	Grain	€
F 2116	D 91	65,1
F 2116	D 126	65,1
F 2116	D 181	65,1

4

Needle-point files handles

H 400 / H 500

H 400 -
Material: Plastics. L = 80 mm.
Clamping range: 2,3 to 4 mm

H 500 -
Material: Plastics with pressure rotary clamping device. L = 96 mm.
Clamping range: 2 to 3,1 mm



REF	€
H 400	2,3



REF	€
H 500	19,14



ZF 9 ...

Micro-diamond files, conical

D54, D64

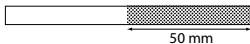

D76, D91

D107, D126

Total length: 100 mm

	REF	Grain	€	Coating
	ZF 90 D54		12,62	
	ZF 90 D64		12,62	
	ZF 90 D76		12,62	
	ZF 90 D91		12,62	
	ZF 90 D107		12,62	
	ZF 90 D126		12,62	
	ZF 91 D54		12,62	
	ZF 91 D64		12,62	
	ZF 91 D76		10,52	
	ZF 91 D91		12,62	
	ZF 91 D107		12,62	
	ZF 91 D126		12,62	
	ZF 92 D54		12,62	
	ZF 92 D64		12,62	
	ZF 92 D76		12,62	
	ZF 92 D91		12,62	
	ZF 92 D107		12,62	
	ZF 92 D126		12,62	
	ZF 93 D54		12,62	
	ZF 93 D64		12,62	
	ZF 93 D76		12,62	
	ZF 93 D91		12,62	
	ZF 93 D107		12,62	
	ZF 93 D126		12,62	
	ZF 94 D54		12,62	
	ZF 94 D64		12,62	
	ZF 94 D76		12,62	
	ZF 94 D91		12,62	
	ZF 94 D107		10,52	
	ZF 94 D126		12,07	
	ZF 99 5P D54		63,81	Set of micro-diamond files = 5 p.
	ZF 99 5P D64		63,81	
	ZF 99 5P D76		63,81	
	ZF 99 5P D91		63,81	
	ZF 99 5P D107		63,81	
	ZF 99 5P D126		63,81	



Diamond files, conical, electro-bonded





KD 160 ...

- Total length: 170 mm
- Thickness: 0,5-2,0 mm conical
- Coating length: 110 mm

 **D54, D64**

 **D126**

 **D181**

	REF	€	a / a ₁
	KD 1601 D 54	16,93	3 / 2
	KD 1601 D 64	17,31	
	KD 1601 D 126	17,31	
	KD 1602 D 54	15,87	4 / 3
	KD 1602 D 64	18,04	
	KD 1602 D 126	15,87	
	KD 1603 D 54	19,51	6 / 6
	KD 1603 D 64	19,51	
	KD 1603 D 126	20,25	
	KD 1603 D 181	•	8 / 8
	KD 1604 D 54	22,08	
	KD 1604 D 64	22,08	
	KD 1604 D 126	21,35	
	KD 1604 D 181	26,17	

4

Diamond files, conical, electro-bonded, set

KD 1600

Includes:

Set of 10 conical diamond files.

- 2x KD 1602 D 126
- 2x KD 1602 D 64
- 2x KD 1603 D 64
- 1x KD 1601 D 64
- 1x KD 1602 D 54
- 1x KD 1604 D 64
- 1x KD 1604 D 54



REF	€
KD 1600	174,89



F 12 ...

Diamond files with grip, electro-bonded

- D91
- D126
- D181

- Total length: 215 mm
- Coating length: 100 mm

	REF Grain	€	Coating
	F 120 D 91	48,96	
	F 120 D 126	48,6	
	F 120 D 181	48,96	
	F 121 D 91	39,76	
	F 121 D 126	39,76	
	F 121 D 181	39,76	
	F 122 D 91	39,76	
	F 122 D 126	39,76	
	F 122 D 181	•	
	F 123 D 91	48,96	
	F 123 D 126	48,96	
	F 123 D 181	48,96	
	F 124 D 91	48,96	
	F 124 D 126	48,96	
	F 124 D 181	48,96	

F 126

Diamond files with grip, electro-bonded, set

- D91
- D126
- D181



- Includes:
Set of 5 diamond files with grip.
- F 120, F 121, F 122, F 123, F 124

REF	€
F 126 D 91	203,96
F 126 D 126	203,96
F 126 D 181	203,96



Escapement diamond files, electro-bonded

H ...

- Total length: 140 mm
- Coating length: 41 mm



	REF	Grain	€	Coating
	H 609 D 91		17,66	
	H 609 D 126		17,66	
	H 610 D 91		17,66	
	H 610 D 126		17,66	
	H 611 D 91		17,66	
	H 611 D 126		17,66	
	H 614 D 91		17,66	
	H 614 D 126		17,66	
	H 617 D 91		17,66	
	H 617 D 126		17,66	
	H 619 D 91		17,66	
	H 619 D 126		17,66	
	H 621 D 91		17,66	
	H 621 D 126		17,66	

4

Needle-point files handles

H 400 / H 500

H 400 -
Material: Plastics. L = 80 mm.
Clamping range: 2,3 to 4 mm

H 500 -
Material: Plastics with pressure rotary clamping device. L = 96 mm.
Clamping range: 2 to 3,1 mm



REF	€
H 400	2,3



REF	€
H 500	19,14



DR ...

Diamond riffler files, electro-bonded

- D91
- D126
- D181



- Total length: 150 mm
- Coating length on both sides: 25 mm

	REF Grain	€	Coating
	DR 15 D 91	21,35	
	DR 15 D 126	22,08	
	DR 15 D 181	26,5	
	DR 16 D 91	20,25	
	DR 16 D 126	22,08	
	DR 16 D 181	24,65	
	DR 18 D 91	20,25	
	DR 18 D 126	20,61	
	DR 18 D 181	26,17	
	DR 20 D 91	21,35	
	DR 20 D 126	20,99	
	DR 20 D 181	24,65	
	DR 22 D 91	20,25	
	DR 22 D 126	22,08	
	DR 22 D 181	24,29	
	DR 24 D 91	22,08	
	DR 24 D 126	23,56	
	DR 24 D 181	26,5	

R 700

Riffler files handles



Material: Plastics

REF	€
R 700	8,53

