

## TW 222-LR *Liquid Resistant* Global Thinswitch

The **Global Thinswitch** helps prevent accidental mould closure in injection moulds by verifying ejector plate return in injection moulds with 3mm or 4mm rest buttons. A polyurethane dome covers the actuator spring, protecting internal gold switch contacts from environmental contamination and occasional water or oil spray.

A special mounting bracket aids installation from the edge of the mould. The bracket allows moulders to slide the Thinswitch into place without disassembling the mould or using screws to hold the switch in place.

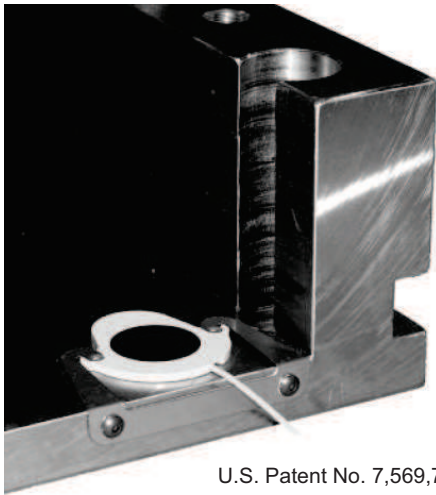

U.S. Patent No. 7,569,783

### Features and Benefits:

- Tested over 14 million cycles
- Can be removed while the mould is in the machine
- 80°C Standard temperature rating
- Adjustable actuation between 3.2mm and 4mm from the switch base (excluding spacer)
- 3mm Thick design fits snugly behind the ejector plate between the rest buttons
- 1mm Spacer (included) may be used on moulds with 4mm rest buttons
- Stripped and tinned 2m wire leads
- Mounting hardware included: M3 x 0.3 screws and bracket

Rated Current (Resistive) at 24VDC vs. Operating Temperature	
Mamps	°C
100	29.4
90	49.0
80	68.3
70	79.4

### Specifications:

Operating Temperature: 80°C/176°F Max  
 Switching: SPST (normally open)  
 Contacts: BeCu with Hard Gold Plating

The **Global Thinswitch** is designed for use in very low power mould protection control circuits. It is not intended to switch inductive loads such as relay or solenoid coils.

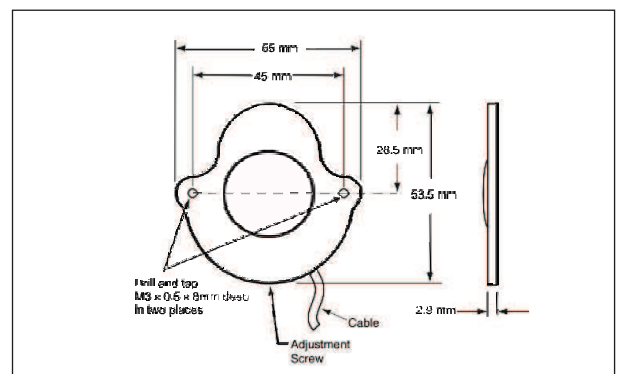

### Materials:

Body: Fibreglass-Reinforced Nylon  
 Dome: Polyurethane  
 Back Cover: Polyester Film  
 Wire Leads: 28ga stranded, 2 conductor, shielded cable, 2m long, ends stripped and tinned.

