

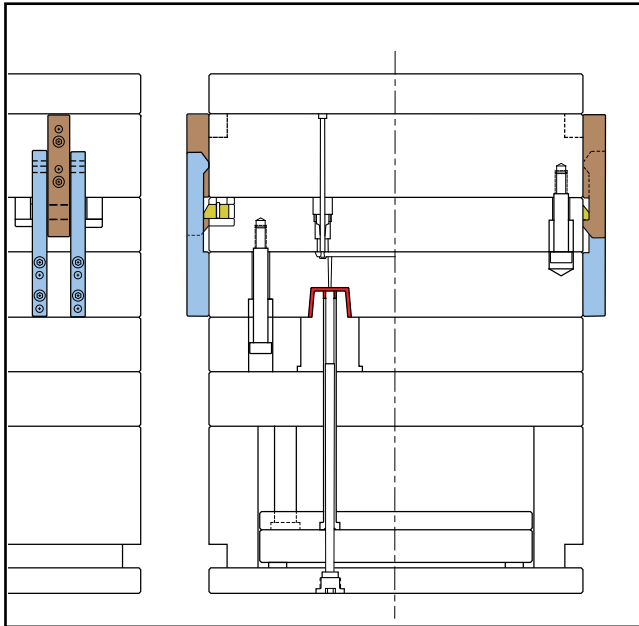

The Cam-Driven External Plate Locks allow for parting line sequencing via a versatile design with minimal machining for different applications, including:

- 3-Plate Sequencing
- Dual Ejection
- Stripper Plate Sequencing



Mold Closed: Lock Engaged

In this 3-plate application, three parting lines are utilized for ejecting the part and runner.

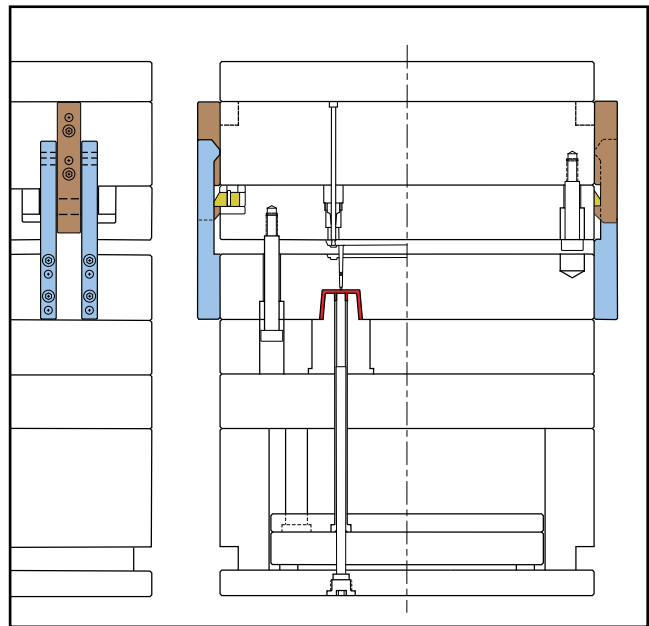

First Parting Line Opens

The Puller Pin pulls the runner and breaks the gate, while parting line #2 is held closed by the Plate Lock.

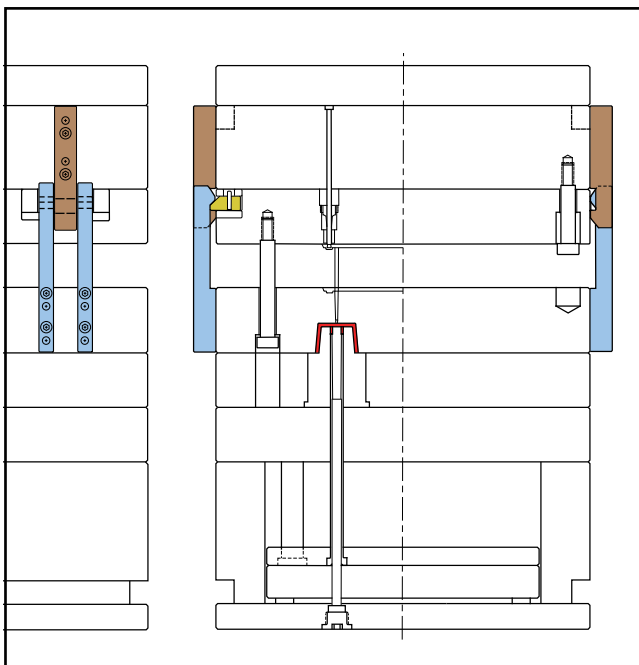

Stroke Continues

The Plate Lock release point is reached and the 2nd parting line begins to open.

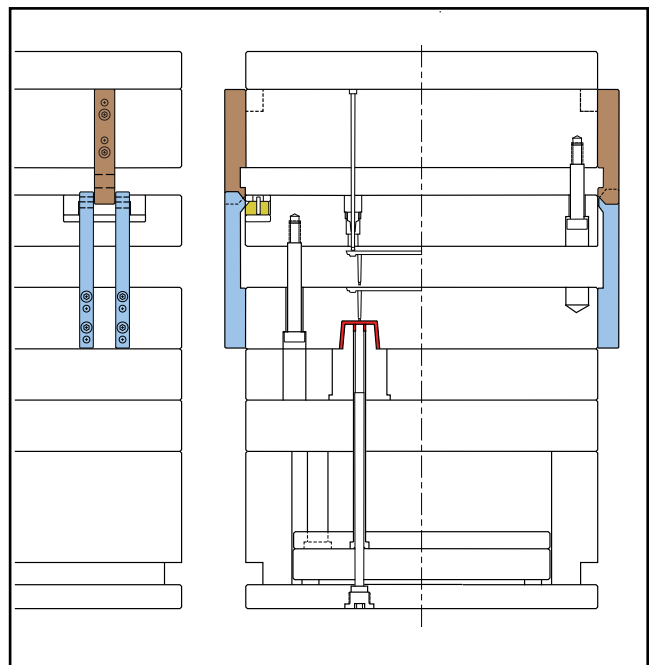

Second Parting Line Opens

With parting line #1 and #2 fully open, the mold continues to open with parting line #3 next, and the part is then ejected.

3-PLATE APPLICATION

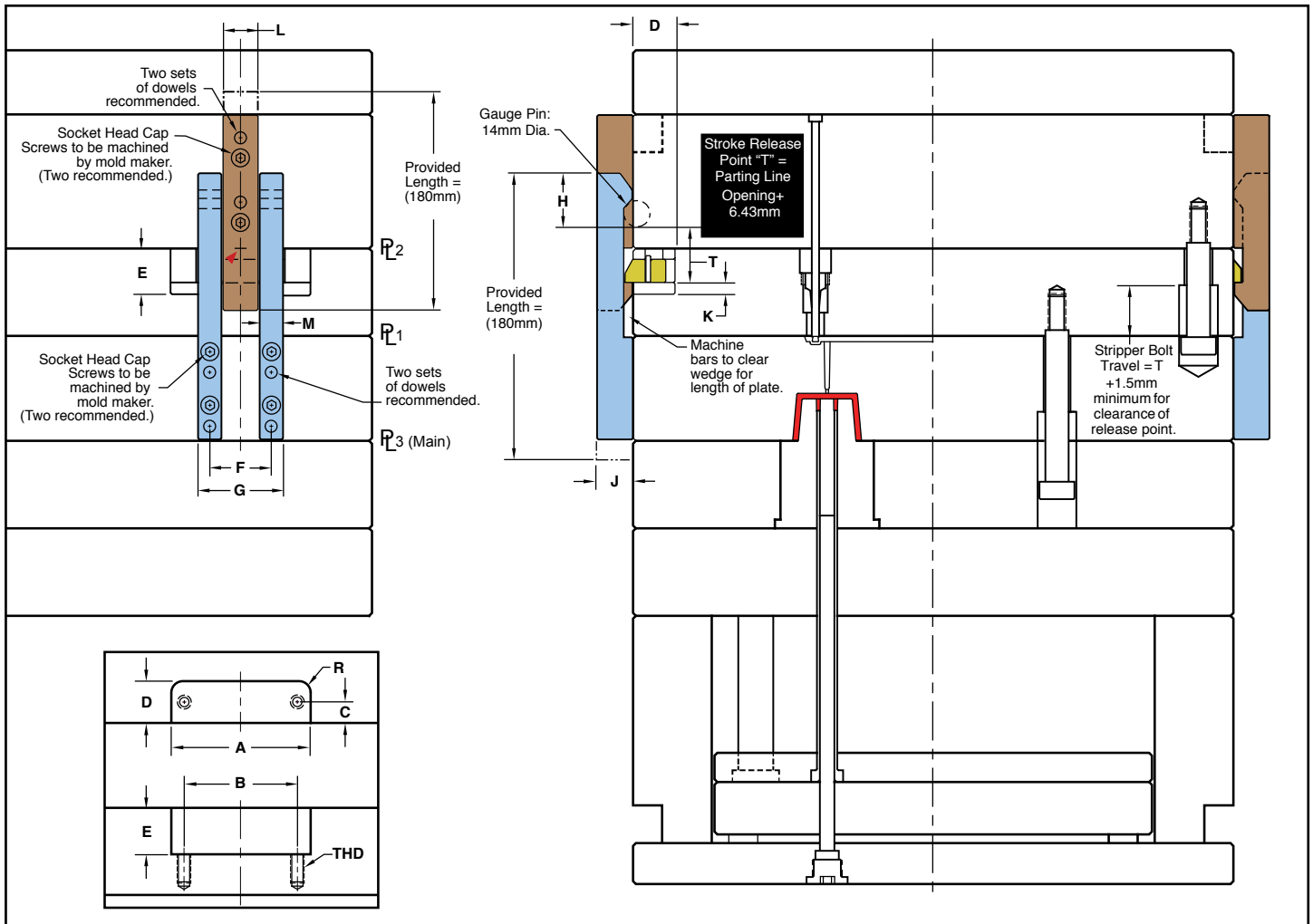

▶ CAD insertion point

Metric Standard

CATALOG NUMBER	A	B	C	D	E	F	G	H	J	K	L	M	R	THD
	+03 -00	±.1	±.1	+03 -00	+03 -00	±.1	REF	REF		+00 -03			Pocket	
PLCM20	80.02	64	12	24	27	35	49	31.55	20	7	20	14	7	M6-1.0 x 10mm Deep

Design & Installation Guidelines:

- Determine the lengths of the Cam Bars by utilizing the gauge pin as shown, calculating the timing with the "T" dimension. Further explanation of the timing is shown at right.
- Machine the Latch Bar to the overall length required with the mold closed, overlapping the Wedge Bar.
- Modify both the Latch Bar and Cam Bars on the plate side to ensure clearance from the runner stripper plate.
- Fasteners should be balanced on the Cam and Latch Bars, utilizing screws and dowels in the suggested locations shown above.
- For stripper plate applications, refer to page D-8. Assembly materials and information can be found on page D-9.

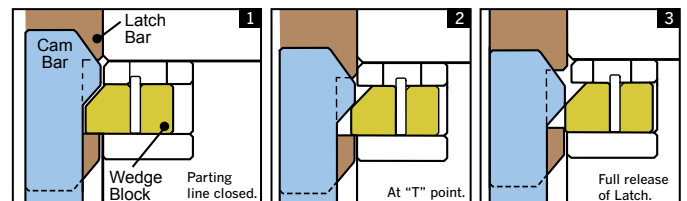

In #1 above, the gap shown between the Cam Bar and the Wedge Block represents the mold open stroke required prior to any contact with the Wedge.
 In #2, the Cam has engaged the Wedge and traveled .203 total in the mold open direction, causing the wedge to retract .100. This is the start of the Latch Bar release from the Wedge, and the plates begin to separate.
 In graphic #3, the Cam has engaged the Wedge and traveled .260 total in the mold open direction, causing the Wedge to retract an additional .045, fully releasing the Latch.

DUAL EJECTION APPLICATION

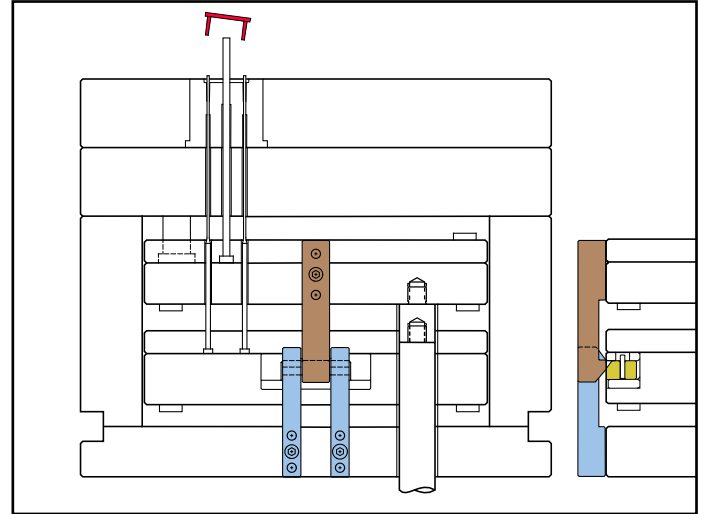
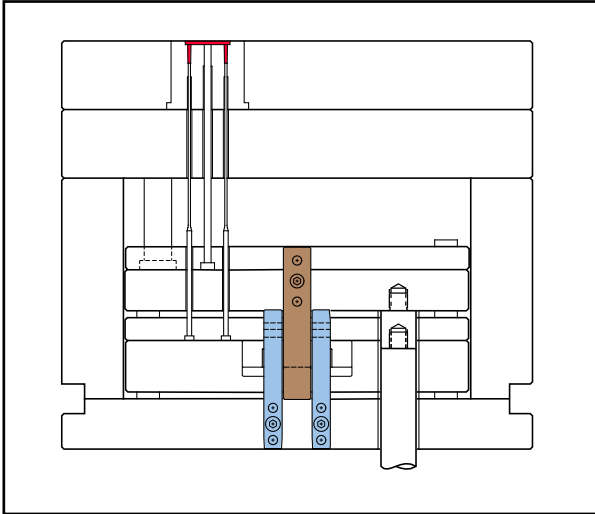

- Utilize Plate Locks for keeping both ejector sets together until preset release point.
- Machine all pockets as shown on the previous page, mounting the Guide Assembly/Wedge Block in the bottom Ejector Plate.

STRIPPER PLATE APPLICATION

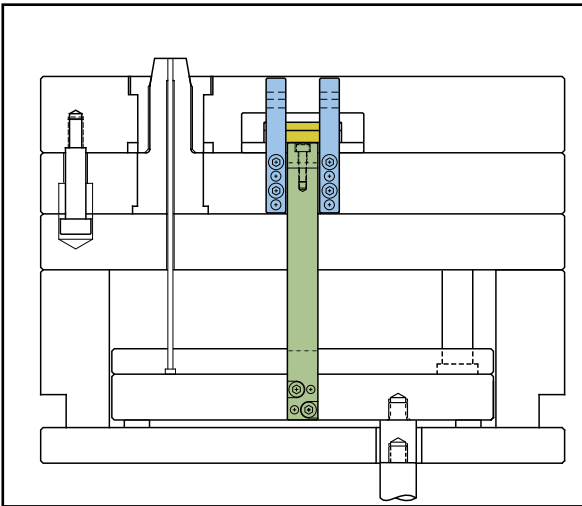

Mold Closed: Stripper Plate Retracted

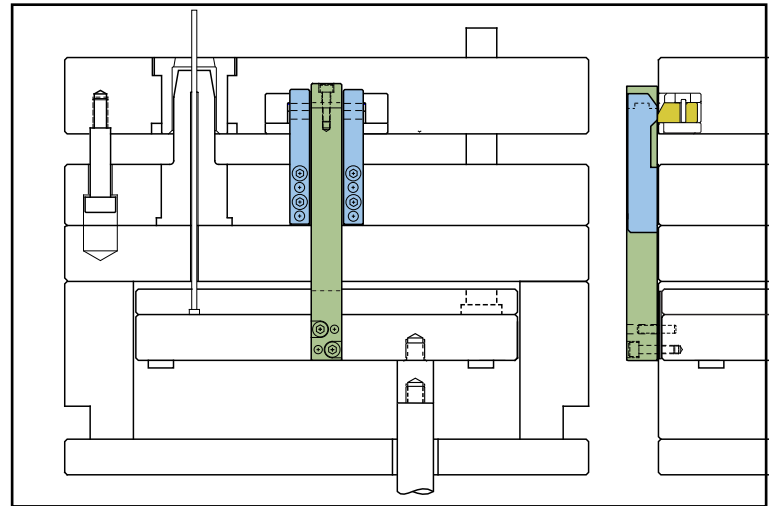

Mold Open: Stripper Plate Released

The Drivers push the stripper plate forward until the parts are stripped from the core. The lock then releases, allowing the ejector pins to push the parts from the stripper plate.

Design & Installation Guidelines:

- Stripper plate applications can be utilized as shown above with the optional Stripper Plate Kit as sold on page D-9. The Latch Bar will be discarded and replaced with the Driver, Cap, and Spacer offered in the kit.
- All pocket and component machining is similar to the 3-plate application shown on page D-7 except for calculation of the "T" dimension for timing the release point according to the graphic at right.
- Use the Spacer as a template for machining the bolts/dowels on the Driver/Cap assembly.
- Attach the Spacer to the Driver, which will provide .03"/.75mm gap between the Driver and the mold to avoid interference.
- Install all components as shown.

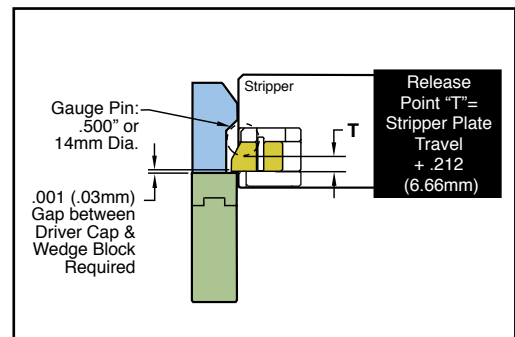

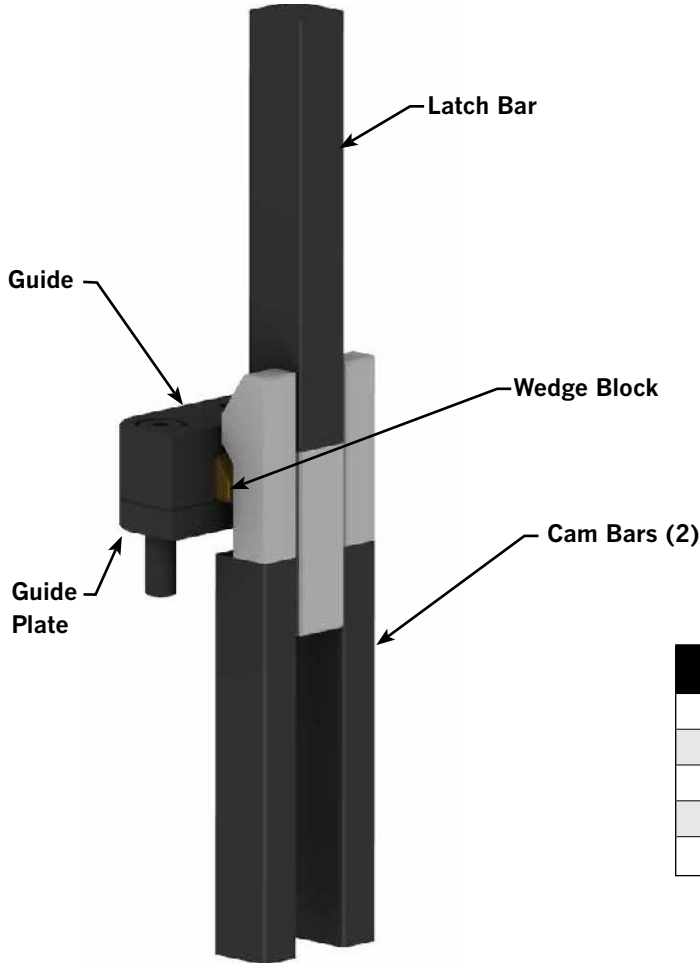

CATALOG NUMBER	DESCRIPTION
PLC75	External Plate Lock Assembly: Inch
PLCM20	External Plate Lock Assembly: Metric

Assembly includes:

- All five machined components listed below.
- Compression Springs (2)
- 1/4-20 LHCS/M6-1.0 LHCS (2-Within Housing)
- ø1/8/ø3mm Dowel Pin (Within Housing)

PART NAME	MATERIAL/TREATMENT
Latch Bar	4340, 35-40 HRC, Nitrided/Black Oxide
Cam Bar (2)	4340, 35-40 HRC, Nitrided/Black Oxide
Wedge Block	A-2, 58-60 HRC Titanium Nitrided
Guide	H-13, 52-54 HRC Nitrided/Black Oxide
Guide Plate	H-13, 52-54 HRC, Nitrided/Black Oxide

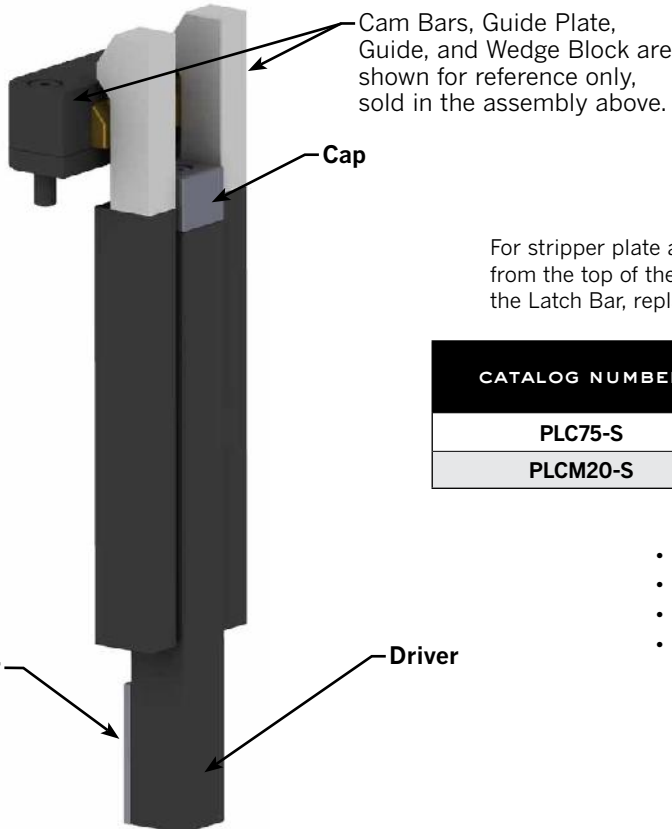

**PLATE LOCKS
STRIPPER PLATE KIT**

For stripper plate applications, purchase the appropriate metric or inch assembly from the top of the page and the matching kit below. The mold maker will discard the Latch Bar, replacing it with the Cap/Driver/Spacer shown at left.

CATALOG NUMBER	DESCRIPTION
PLC75-S	Stripper Plate Kit: Inch
PLCM20-S	Stripper Plate Kit: Metric

- Cap (4340, 34-38 HRC, Nitrided)
- Driver (4140, 28-35 HRC, Black Oxide)
- Spacer (303 Stainless, 35-40 HRC)
- (1) #10-32 x .75/M5-.8 x 30mm SHCS for the Cap/Driver assembly.