

The CamAction is a component that incorporates the elements of a traditional slide (slide, angle pin, heel block) into one compact, off-the-shelf unit. It provides the ability to mould detail features into the side of a moulded part. Easy to install, it reduces lead time and labour when manufacturing moulds. Units have been tested in use to over a million cycles.

### Metric Standard

Note: All dimensions and tolerances are in millimeters.

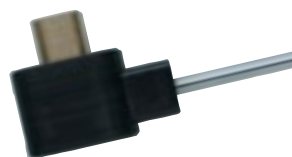
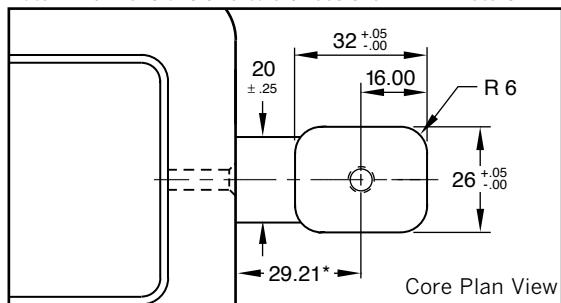

Note: When the core pin is not shutting off on the inner core wall, the distance from the edge of the insert should be 29.02 for the slide carrier to shut off against the core insert.

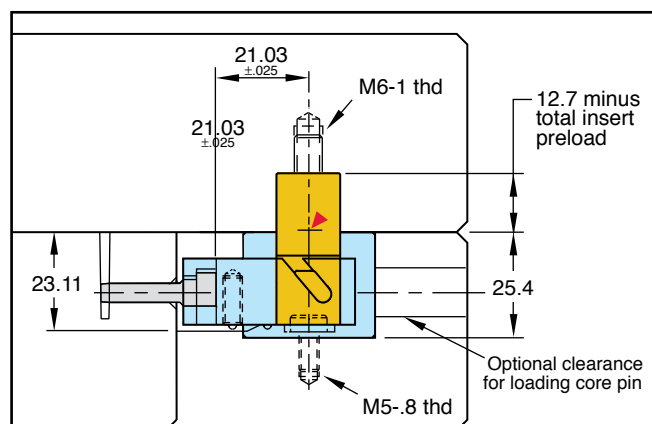
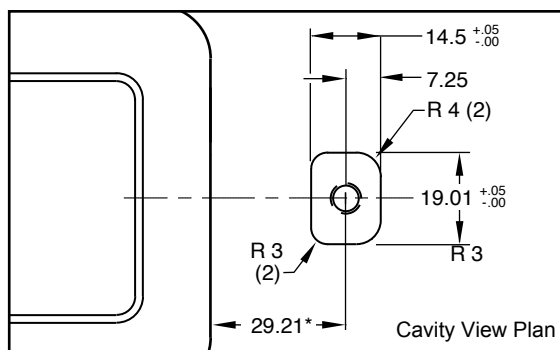

Note: 21.03 dimension must be maintained to ensure proper shut-off.

Travel = 5.8mm

► CAD insertion point

CATALOG NUMBER	DESCRIPTION
<b>CAMM-200</b>	Metric CamAction Unit-Standard Driver
<b>CAMM-200L</b>	Metric CamAction Unit - Longer Driver

Note: Longer driver allows for extension below parting line up to 76mm.

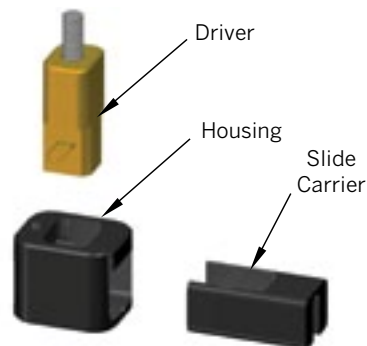

Replacement parts are available. Refer to the price list for catalog numbers and pricing, and contact Customer Service for availability.

100/200 SERIES CORE PINS

**M** M-2 **H** 60-62 HRC **S** Chrome Plated

CATALOG NUMBER	D	H	Y1	Y2
<b>CAPMM-5</b>	4.994 mm 5.006 mm	9.5 mm	12.7 mm	19.05 mm
<b>CAPMM-10</b>	9.984 mm 9.992 mm	9.5 mm	12.7 mm	17.40 mm

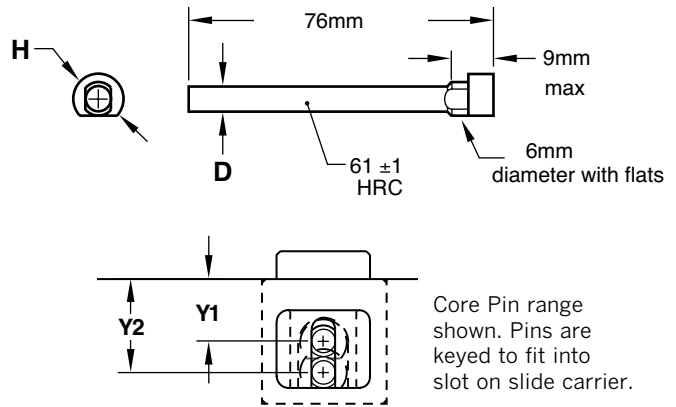

For use with 100 and 200 Series CamActions.  
When using with the 100 Series, 50.8mm draft per side (minimum) is required in the molding area.

200 SERIES CORE PINS

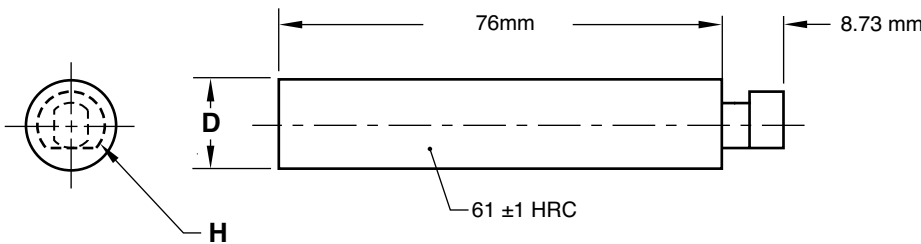

**M** M-2 **H** 60-62 HRC **S** Chrome Plated

CATALOG NUMBER	D	H
<b>CAP2MM-13</b>	13.002 mm 13.007 mm	9.5 mm

For use with 200 Series CamActions only.

200 SERIES INSERTS

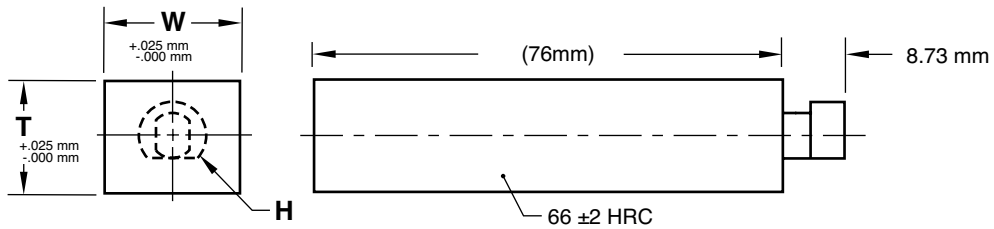

**M** P-20 Pre-Hard **S** Salt Bath Nitride (SBN)

CATALOG NUMBER	T	W	H
<b>CSE2MM-16X19</b>	16 mm	19 mm	9.5 mm

For use with 200 Series CamActions only.

“A” EXTENSION

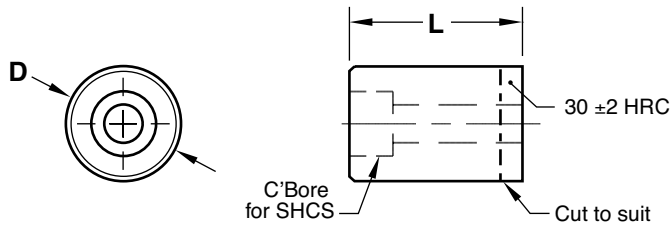

**M** 4140 **H** 28-32 HRC **S** Black Oxide

CATALOG NUMBER	D	L	SHCS
CAEMM-100	19 mm	28 mm	M6-1

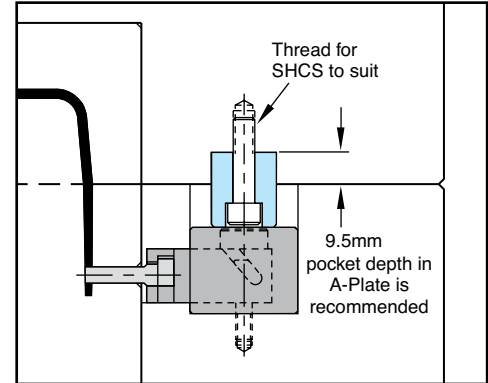

“B” RISER

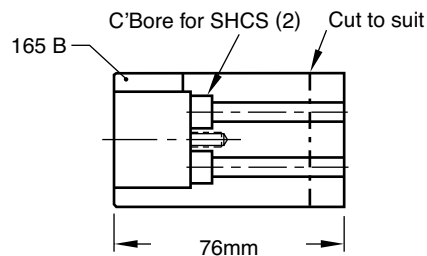
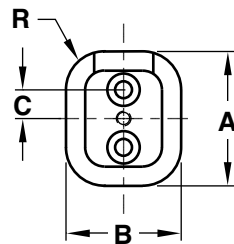

**M** AISI 12L17 **H** 165 Brinell **S** Black Oxide

CATALOG NUMBER	A	B	C	R	SHCS
CBRMM-100	44 mm	38 mm	10 mm	12.7 mm	M6-1

