

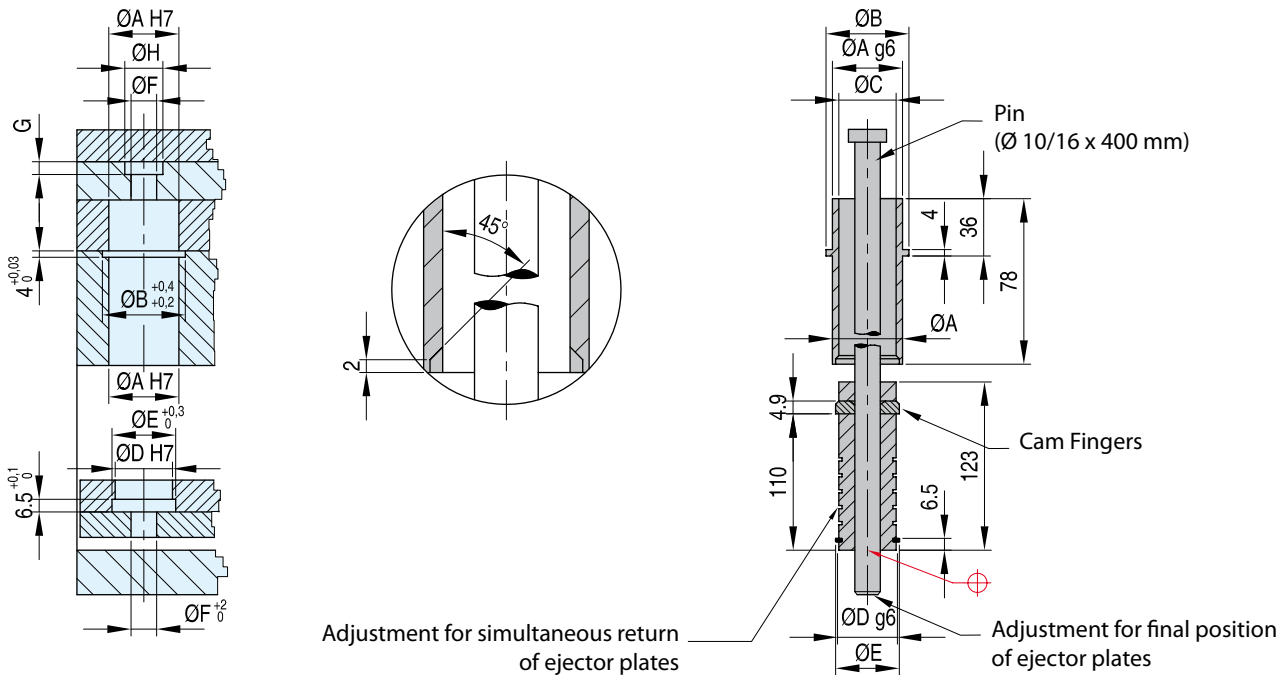

**Operation facilities:**

- injection and diecasting molds
- prevents damage of mold cavities and ejectors
- valve plates
- molds with multistage mold releasing movement
- Early ejector return assemblies save you time and money.
- Unique design permits low costs.
- Long life due to precise parts and hardened surfaces.
- Prevents valuable mold components from mechanical damage.



REF	A	B	C	D	E	F	G	H
ER 100 E	32	35	24,2	24	27	10	5	17
ER 101 E	42	46	32,2	32	36	16	7	24



Dimensions for installation in **DME** standard molds

ER

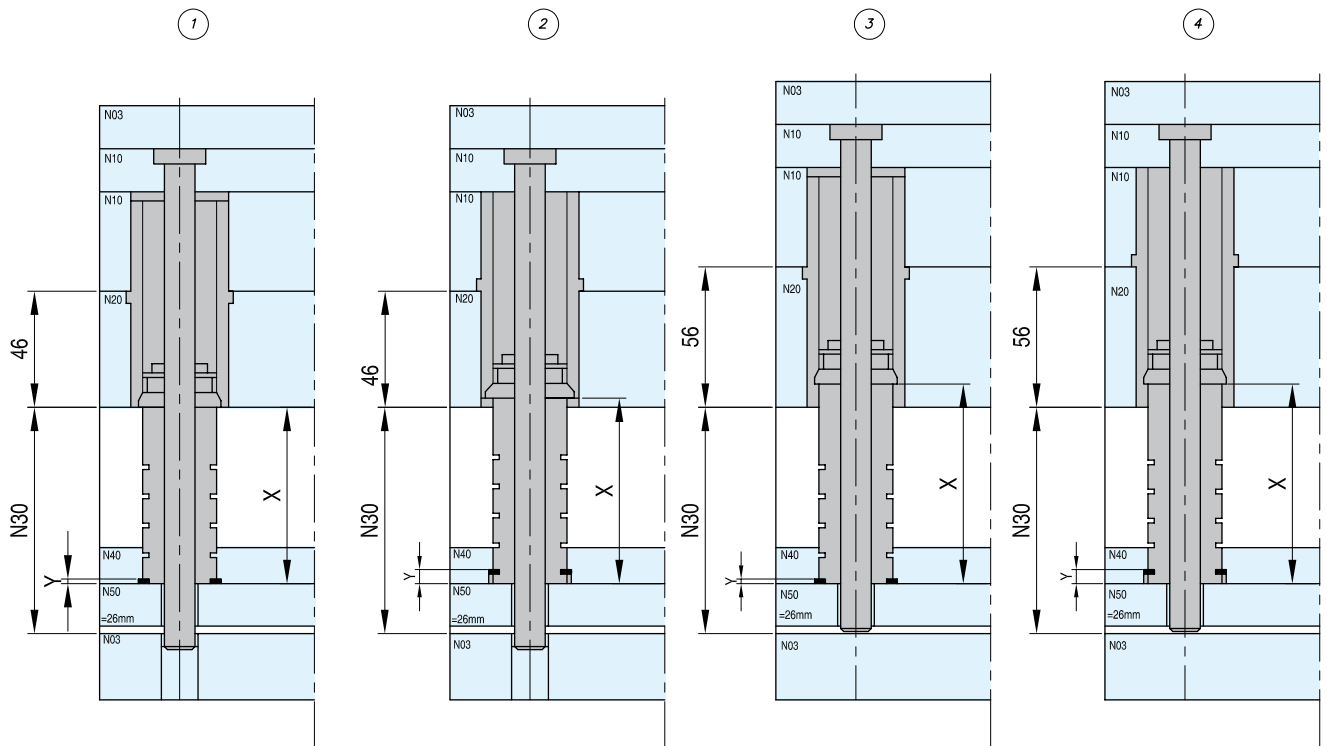

Ex.N30	X 1	Y 1	X 2	Y 2	X 3	Y 3	X 4	Y 4
<b>66</b>	36	2,5	40	6,5	46	2,5	50	6,5
<b>86</b>	56	2,5	60	6,5	66	2,5	70	6,5
<b>106</b>	76	2,5	80	6,5	86	2,5	90	6,5
<b>126</b>	96	2,5	100	6,5	106	2,5	110	6,5

- Four units minimum per mold are preferred. Two units per mold mounted on the centerline of the mold are a must.
- Use guided ejection in the ejector assembly.
- Use only in a horizontal press.
- If used in an unbalanced mold. Uneven loading could occur.
- Lubricate occasionally with a lithium type grease.
- Timing is critical: all units to be timed within  $\pm 0,013$ mm of one another.
- No preload of unit.

CAD reference point

Spare Parts			
Bushing	Post	Pin	Set: cam finger washer, upper and lower snap ring
<b>ERB 100 E</b>	<b>ERS 100 E</b>	<b>EPA 05</b>	<b>ER 100 RK E</b>
<b>ERB 101 E</b>	<b>ERS 101 E</b>	<b>EPA 05</b>	<b>ER 101 RK E</b>





View A: Mold closed, molding position. Post and cam fingers must be coordinated, so that the pin can slip into post when ejector plates are in final position.

View B: Mold open, mold release position. During ejection the cam fingers have slipped into bushing and inner diameter is reduced.

View C: Mold closing. Pin is pressing the cam fingers and pushes ejector plates back.

View D: Mold continues closing. Ejector plate has been pushed all the way back. Cam fingers have slipped outward into counterbore in bushing allowing actuator pin to slip by. Mold continues closing until completely closed as in view A.

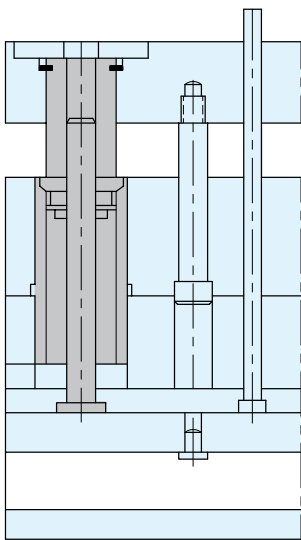
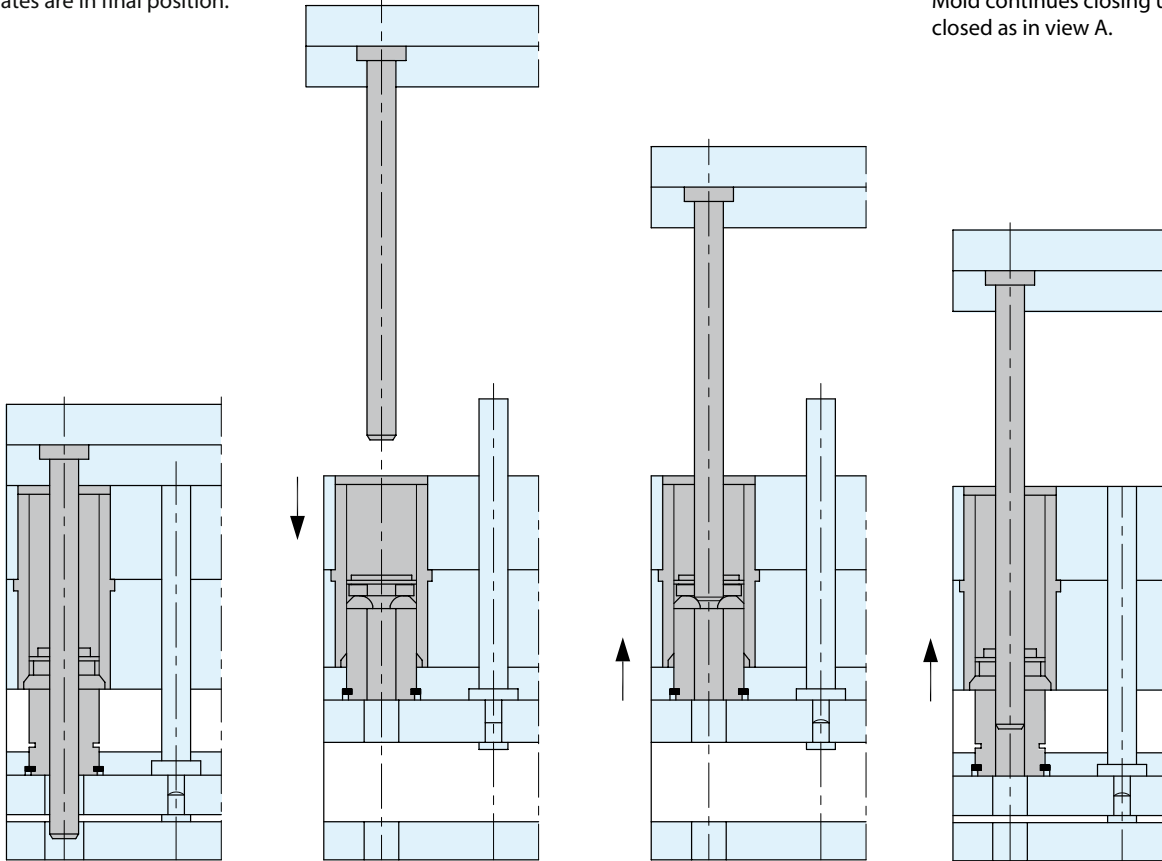

Installation for Ejector pin travel beyond stripper plate. Stripper plate moves forward until cam fingers slip outward into counterbore in bushing and ejector plate continues to travel.